

High Resolution Oscilloscope



The ZT444x Digital Storage Oscilloscope (DSO) Family provides a high resolution of 14 bits and supports industry standards for easy integration into automated test systems. ZT444x's powerful hardware is complemented by its flexible software and Graphical User Interface (GUI) to enhance the instrument's capabilities for new and legacy test requirements. The instrument's on-board signal processing and measurement suite speeds up data acquisition and analysis. The instruments are available in PXI, LXI, and VXI.

FEATURES

- Available in PXI, LXI & VXI platforms
- 2 channels and 4 channels
- 14 bit resolution
- Real time interleaved sample rates up to 800 MS/s
- On-board signal processing
- Compatible with third-party tools such as LabVIEW and LabWindows/CVI

BENEFITS

- High density form factor lowers overall system size and cost
- Platform flexibility promotes integration with various designs and chassis
- On board processing speeds up data acquisition and analysis
- Backed by Teradyne's best-in-class customer support and calibration/repair services

End Markets Served

- Defense & Aerospace
- Medical
- Automotive
- Semiconductor Test
- Telecommunication Test



Example Applications

- High Energy Physics Applications
- Multi-Channel Capture
- Automated Testing of Electronics
- High Speed Test Applications

Part Number	Description
ZT4441PXI	2 Channels in PXI
ZT4441LXI	2 Channels in LXI
ZT4441VXI	2 Channels in VXI
ZT4442LXI	4 Channels in LXI
ZT4442VXI	4 Channels in VXI

Direct Path (DP) and Differential (DF) front end options are also available. Contact Teradyne for more information on DP and DF options.

(For contact information, please refer to page 18.)

Hardware

On Board Signal Processing and Analysis

ZT-Series DSOs include an on-board DSP for signal processing and analysis capability that shortens test cycles and reduces the need for user developed signal processing algorithms. The on board capability is much faster than processing on a separate PC or controller. It also removes the need to transfer large amount of waveform data to an external PC or controller and thereby speeding up post capture analysis. The on board DSP and analysis capability ranges from performing basic mathematical functions to the more complex computations like Fast Fourier Transform (FFT), derivative, integration, histogram, limit testing, mask testing, waveform parameter trending.

On Board Memory

ZT444x DSO provides a significant amount of flexible segmented on-board memory. Segmented memory allows waveforms to be saved on the DSO memory for later analysis and viewing. The memory segments can be viewed either overlaid or individually.

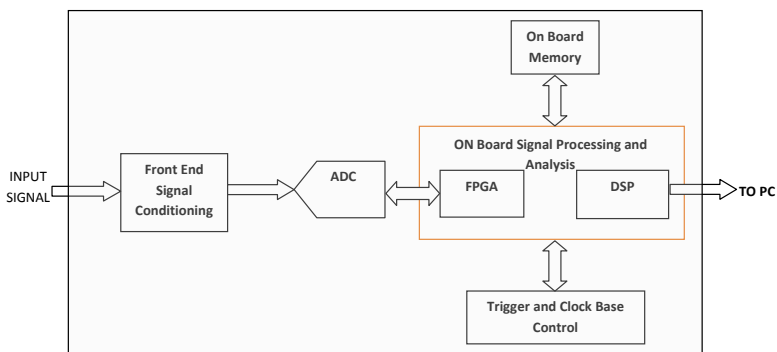

ZT444x Block Diagram

Software

Driver

ZT444x DSO instruments are operated with ZT-Series Driver software that includes API function calls or SCPI commands. The driver can work with the most commonly used application development environments like Microsoft Visual Studio® and LabWindows™/CVI for TPS development or be integrated with 3rd party tools like LabView™.

Easy-to-Use Graphical User Interface

The ZT444x driver software suite includes a Graphical User Interface (GUI) called ZScope™. ZScope is an intuitive software interface that provides manual instrument control and a user experience similar to that of a benchtop oscilloscope. Using ZScope, no more than two clicks are required to access all oscilloscope functions. In addition to the standard oscilloscope measurement functions, ZScope includes built-in advanced measurements such as: limit testing, histogram, FFT, filtering, SNR, spurious free dynamic range, ENOB, total harmonic distortion, measurement trending, and SINAD to name a few.

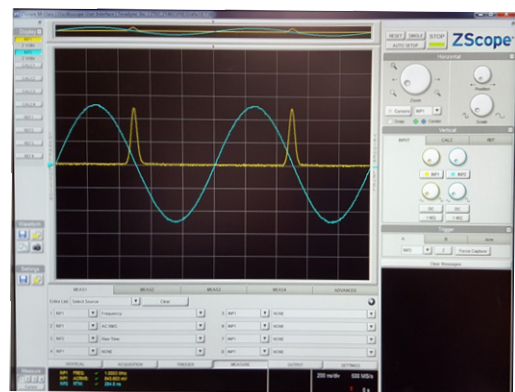

ZScope Graphical User Interface

ZT462x Series Specifications

ZT444x Series specifications are subject to change without any notice. Unless otherwise noted, the specifications of ZT444x Series are warranted at ambient temperature range of 0°C to 50°C.

ZT444x specifications are warranted under the following conditions:

- Instrument is warmed up for 20 minutes at ambient temperature
- Instrument is in the calibration window

Acquisition

Sample Rate:

- 20 kS/s to 400 MS/s, non-interleaved and real-time
- 800 MS/s, interleaved real-time or equivalent-time
- 800 MS/s to 40 GS/s, equivalent-time
- 80 GS/s, interleaved equivalent-time

Any sample rate that is an integer multiple of an available sample rate can be created using interpolation.

Table 1 – Acquisition Mode Sample Rates

Mode(s)	Sample Rate
Non-Interleaved Real-Time	20 kS/s 25 kS/s 40 kS/s 50 kS/s 100 kS/s 200 kS/s 250 kS/s 400 kS/s 500 kS/s 1 MS/s 2 MS/s 2.5 MS/s 4 MS/s 5 MS/s 10 MS/s 20 MS/s 25 MS/s 40 MS/s 50 MS/s 100 MS/s 200 MS/s 400 MS/s
Interleaved or Equivalent Time	800 MS/s

Equivalent Time	1.6 GS/s 2.4 GS/s 4 GS/s 8 GS/s 16 GS/s 20 GS/s 40 GS/s
Interleaved Equivalent-Time	80 GS/s

Table 2 – Acquisition Specifications

Specification	Value
Non-Interleaved Acquisition	
ZT4441	2 channels @ up to 400 MS/s real-time
ZT4442	4 channels @ up to 400 MS/s real-time
Interleaved Acquisition	
ZT4441	1 channel @ up to 800 MS/s real-time
ZT4442	2 channels @ up to 800 MS/s real-time
Sampling Modes	Normal: single-shot acquisition Average: multiple-capture acquisition Envelope: multiple-capture minimum & maximum detection Equivalent Time: multiple-capture, high-rate reconstruction Peak Detect: single-shot 10x over-sampling envelope detection High Resolution: single-shot 10x over-sampling averaging Fast: Multiple acquisitions
Multiple-Capture Count	2 to 65,536 waveforms in powers of 2
Acquisition Re-Arm Time	≤ 5 μs
Maximum Record Length Memory	
Non-Interleaved	128 MiSamples
Interleaved	256 MiSamples
Minimum Waveform Size	10 Samples
Maximum Waveform Size	
Normal or Fast Acquisition Mode	Maximum Record Length (above)
All Other Modes	512 KiSamples
Segmented Memory	View & compare history of previous waveforms in memory View component waveforms when averaging
Maximum Segments	32 Ki waveforms @ ≤ 4 KiSamples
Total Memory	
ZT4441	256 MiSamples
ZT4442	512 MiSamples

Vertical Input Channels

Table 3 – Input Channel Specifications

Specification	Value
Number of Channels	
ZT4441 (interleaved acquisition)	Quantity 1
ZT4441 (non-interleaved acquisition)	Quantity 2
ZT4442 (interleaved acquisition)	Quantity 2
ZT4442 (non-interleaved acquisition)	Quantity 4
Connectors	BNC
Maximum Input (50 Ω)	± 5 V (DC + peak AC) CAT I Input load protection at ±6 VDC
Maximum Input (1 MΩ)	± 210 V [DC + peak AC (<100 kHz)], CAT I Peak AC, de-rated 20 dB/decade above 100 kHz

Full Scale Input Range & Offset Adjust

Table 4 – Full Scale Input Range & Offset Adjust Value

Impedance	Range	Full Scale	Offset	Maximum Range + Offset
1 MΩ	5 V/div	50 Vpp	0 V	± 25 V
	2.5 V/div	25 Vpp	± 12.5 V	± 25 V
	1 V/div	10 Vpp	± 10 V	± 15 V
	500 mV/div	5 Vpp	± 10 V	± 12.5 V
	200 mV/div	2 Vpp	± 2 V	± 3 V
	100 mV/div	1 Vpp	± 2 V	± 2.5 V
	40 mV/div	400 mVpp	± 400 mV	± 600 mV
	20 mV/div	200 mVpp	± 400 mV	± 500 mV
	10 mV/div	100 mVpp	± 400 mV	± 450 mV
	5 mV/div	50 mVpp	± 400 mV	± 425 mV
	2.5 mV/div	25 mVpp	± 400 mV	± 412.5 mV
	1.25 mV/div	12.5 mVpp	± 400 mV	± 406.25 mV
	50 Ω	1 V/div	10 Vpp	0 V
500 mV/div		5 Vpp	± 2.5 V	± 5 V
200 mV/div		2 Vpp	± 2 V	± 3 V
100 mV/div		1 Vpp	± 2 V	± 2.5 V
40 mV/div		400 mVpp	± 400 mV	± 600 mV
20 mV/div		200 mVpp	± 400 mV	± 500 mV
8 mV/div		80 mVpp	± 80 mV	± 120 mV
4 mV/div		40 mVpp	± 80 mV	± 100 mV
2 mV/div		20 mVpp	± 80 mV	± 90 mV
1 mV/div		10 mVpp	± 80 mV	± 85 mV

Technical Notes:

- Magnification is used below 4mV/div range for 50 Ω. Full-scale range for accuracy specifications is defined as 40

mV. Magnification is used below 20 mV/div range for 1 M Ω . Full-scale range for accuracy specification is defined as 200 mV.

- Full-scale range assumes 10 divisions.

Inputs

Table 5 – Input Specifications

Specification	Value
Analog Bandwidth	DC to 300 MHz typical, 250 MHz minimum
Rise Time	1.15 ns
Slew Time	2 kV/ μ s
Impedance	1 M Ω 12 pF or 50 Ω \pm 1% accuracy
Input Bias	
50 Ω	$\leq \pm 10 \mu$ A
1 MΩ	$\leq \pm 1$ nA
DC Gain Accuracy	$< \pm 0.25\%$ full scale range
DC Offset Accuracy (+25° C)	
50 Ω	$< \pm (0.25\% \text{ full scale range} + 0.5\% \text{ offset} + 1 \text{ mV})$
1 MΩ	$< \pm (0.25\% \text{ full scale range} + 0.5\% \text{ offset} + 5 \text{ mV})$
DC Offset Drift (per °C)	$< \pm (0.01\% \text{ full scale range})$
Input VSWR (50 M Ω)	$\leq 1.3:1$, DC to 250 MHz
Analog Filter	20 MHz or Bypass Filter Stopband Rejection: approx. 3 dB @ 20 MHz
Probe Attenuation	0.9 to 1000:1
Coupling	DC or AC
AC Coupling	
50 Ω	200 kHz high-pass
1 MΩ	1 Hz high-pass
Channel-to-Channel Isolation	
DC to 100 MHz	≥ 60 dB
100 MHz to 250 MHz	≥ 50 dB
Typical RMS Noise (ZT4440)	
50 Ω (Full Bandwidth)	0.05% of full scale range + 350 μ V
50 Ω with 20 MHz Filter	0.025% of full scale range + 35 μ V
1 MΩ (Full Bandwidth)	0.05% of full scale range + 3 mV
1 MΩ with 20 MHz Filter	0.025% of full scale range + 500 μ V

Digital Resolution (ZT4440)	14 bits (0.006% of full scale) Up to 32 bits with averaging
-----------------------------	--

Technical Notes:

- Rise time is calculated from $t_r = 0.35/\text{bandwidth}$.

Dynamic Range (500 MS/s, 10.7 MHz Typical)

Table 6 – Dynamic Range Specifications

50 Ω Input Range	Signal-to-Noise Ratio (SNR)	Total Harmonic Distortion (THD)	Signal-to-Noise & Distortion (SINAD)	Spurious Free Dynamic Range (SFDR)
10 Vpp	61.2 dBc	-62.8 dBc	58.9 dBc	65.0 dBc
5 Vpp	59.0 dBc	-64.3 dBc	57.9 dBc	65.0 dBc
2 Vpp	60.0 dBc	-62.8 dBc	58.2 dBc	65.0 dBc
1 Vpp	58.2 dBc	-64.3 dBc	57.3 dBc	65.0 dBc
400 mVpp	55.7 dBc	-64.1 dBc	55.1 dBc	65.0 dBc
200 mVpp	50.5 dBc	-64.9 dBc	50.4 dBc	63.3 dBc
80 mVpp	49.4 dBc	-63.9 dBc	49.3 dBc	55.5 dBc
40 mVpp	43.5 dBc	-63.1 dBc	43.4 dBc	48.9 dBc

Horizontal

Table 7 – Horizontal Specifications

Specification	Value
Sweep Time Range	12.5 ns to 100 s (1.25 ns/div to 10 s/div)
Sweep Time Resolution	10 ns to 10 ms dependent on sweep points and sample rate
Horizontal Position	
Pre-Trigger	0 to 100% of acquisition window
Post-Trigger	0 to 10,000*Gate Resolution
Channel-to-Channel Skew	Channels at same input settings
Channels 1-to-2, 3-to-4	≤ 100 ps
Channels 1-to-3, 1-to-4, 2-to-3, 2-to-4	≤ 200 ps
Skew Adjust	± 10 μs channel-to-channel skew adjustment 1 sample interval resolution ± 1 sample interval accuracy
Timebase Reference	10 MHz
Timebase Reference Source	Internal TCXO, External Input, Backplane (PXI/VXI), Timing Expansion Connector (PCI)
Internal TCXO Timebase	± 2.5 ppm accuracy

Timebase Output	External Output, Timing Expansion Connector Reference I/O (PCI)
-----------------	---

Technical Note:

- Horizontal time range assumes 10 divisions for horizontal axis.

Trigger

Table 8 – Trigger Specifications

Specification	Value
Sweep Modes	Auto or Normal triggered
Trigger Source	Channels 1 to 4, External Input, Pattern, Software, TTL Trigger 0-7, Star Trigger (PXI/PCI), ECL Trigger 0-1 (VXI)
Trigger Slope/Polarity	Positive or Negative
Trigger B	Qualify trigger on second source for edge trigger event
Trigger A Holdoff	Programmable delay after trigger A before recognizing next trigger A event
Trigger B Holdoff	Programmable delay after trigger A before recognizing trigger B event
Trigger A/B Holdoff Range	0 to 100 seconds
Trigger A/B Event Counter	Qualify trigger on N_{th} Trigger event, N=1 to 65,536
Trigger A Modes	Edge, Pattern, State, Pulse Width, Video
Trigger B Modes	Edge, Pattern
Pattern Trigger Mode	Pattern match true or false
Pattern Sources	Channels 1 to 4, External Input, TTL Trigger 0-7, Star Trigger (PXI/PCI), ECL Trigger 0-1 (VXI)
State Trigger Mode	Edge event when pattern match true or false. Pattern source used as Arm qualifier.
Pulse Width Trigger Mode	Trigger on pulse width greater than, less than, within, or outside limits < Limit 1, > Limit 1, Limit 1 < width < Limit 2, Limit 1 > width > Limit 2
Pulse Width Limits	10 ns to 500 ms 5 ns resolution ± 5 ns accuracy
Pulse Width Minimum	2 ns pulse width captured for < Limit1
Video Trigger Mode	PAL (50 Hz), NTSC (60 Hz), SECAM (50 Hz) Standard, Field, Line selectable
Trigger Timestamp	100 ns resolution, 1 second rollover

Trigger, Analog Input

Table 9 – Analog Input Trigger Specifications

Specification	Value
Analog Input Triggers	Channels 1 to 4
Trigger Level	(offset - full scale range/2) to (offset + full scale range/2)
Trigger Hysteresis	2.5% (overdrive required)
Trigger Level Resolution	0.025% of full scale range
Trigger Level Accuracy	± (2% full scale range + 5 mV + offset accuracy)
Trigger Sensitivity	
DC to 100 MHz	5% of full scale range
> 100 MHz	10% of full scale range
Trigger Bandwidth	DC to 300 MHz typical, DC to 250 MHz minimum
Glitch Detection	≥ 500 ps glitch captures in edge trigger mode

Arm

Table 10 – Arm Specifications

Specification	Value
Functionality	Arm to qualify Trigger Event
Source	External Input, TTL Trigger 0-7, Star Trigger (PXI/PCI), ECL Trigger 0-1 (VXI), Software
Polarity	Positive or Negative

External Input (Front Panel)

Table 11 – Front Panel External Input Specifications

Specification	Value
Functionality	Trigger Input, Timebase Reference Input, External Arm
Absolute Maximum Input (no damage)	≤ ± 5 V (DC + peak AC), CAT I
Input Trigger Level Adjustment	-2 V to +2 V 0.5 mV resolution ≤ 20 mV accuracy 20 mV overdrive (input hysteresis)
Input Bandwidth (-3 dB) DC	≥ 250 MHz
Input Impedance	1 MΩ 30 pF or 50 Ω ≤ ± 2% accuracy
Connector	

PXI	SMB
VXI/LXI	BNC

External Output (Front Panel)

Table 12 – Front Panel External Output Specifications

Specification	Value
Functionality	Trigger Output, Timebase Reference Output, Event Output, Programmable Clock Output, Programmable Pulse Output, Constant Level, and Probe Compensation Output
Output Event Source	Arm Event, Trigger A Event, Trigger B Event, Trigger Complete Event, Capture Complete Event, Operation Complete Event, Master Summary Status Event, Limit Test Successful Event
Polarity	High or Low Truth
Programmable Event Pulse Width	50 ns to 163 ms
Programmable Clock	Period: 26.667 ns to 100 seconds 50% Duty Cycle
Programmable Pulse	
Pulse Repetition	26.667 ns to 100 seconds
Interval Pulse Width	26.667 ns
Probe Compensation	10 kHz Clock which can be used to compensate probes
Limit Test Successful	Event pulse after each capture upon limit or mask test success
Output Level	TTL Compatible into $\geq 200 \Omega$ $\geq \pm 24$ mA Output Drive
Output Enable	Tri-State Output Capability
Connector	
PXI	SMB
VXI/LXI	BNC

Backplane Triggers

Table 13 – Backplane Trigger Specifications

Specification	Value
Functionality	Multi-Instrument Synchronization Trigger, Event Output Signals
Triggers	TTL Trigger 0-7, ECL Trigger 0-1 (VXI)
Direction	Input or Output
Source	Arm Event, Trigger A Event, Trigger B Event, Trigger Complete Event, Capture Complete Event, Operation Complete Event, Master Summary Status Event, Constant Level

Polarity	High or Low Truth
Programmable Event Pulse Width	50 ns to 163 ms

Measurements

Table 14 – Measurements Specifications

Specification	Value
Measurements	AC RMS, Amplitude, Average, Cycle Average, Cycle Frequency, Cycle Period, Cycle RMS, DC RMS, Duty Cycle High, Duty Cycle Low, ENOB, Number of Falling Edges, Fall Crossing Time, Fall Overshoot, Fall Preshoot, Fall Time, Frequency, High, Low, Maximum, Mid, Minimum, Peak-to-Peak, Period, Phase, Pulse Width Positive, Pulse Width Negative, Number of Rising Edges, Rise Crossing Time, Rise Overshoot, Rise Preshoot, Rise Time, SFDR, SINAD, SNR, Standard Deviation, THD, Time of Maximum, Time of Minimum
Edge Measurements	N_{th} edge selectable, N = 1 to 65,535
Maximum Measurements	N_{th} maximum selectable, N = 1 to 100 Applies to Maximum and Time of Maximum
Measurement Methods	Entire waveform, Gated by Time, Gated by Points, Gated by Frequency, Gated by Cursors
Measurement Levels	Low, Mid, High reference levels for edge measurements set in absolute voltages or relative percentages
Cursors	Quantity 2 Horizontal & vertical axis location markers X, Y, ΔX , ΔY Measurements
Measurement Lists	Quantity 4 Up to 8 measurements per list that are performed upon acquisition Stored for rapid measurement setup
Measurement Trending	Historic buffer of measurement data stored in Calculate channel (see Calculations)
Measurement Accuracy	
Delta DC Voltage	\pm DC gain accuracy
Absolute DC Voltage	\pm (DC gain accuracy + offset accuracy)
Time	\pm time resolution
Frequency	\pm (1/(period of applied signal \pm time resolution))

Technical Note:

- The resolution = one sample interval, one equivalent-time sample interval, or one interpolated-time sample interval (depending upon acquisition mode).

Reference Waveforms

Table 15 – Reference Waveforms Specifications

Specification	Value
Reference Channels	Quantity 4
Reference Storage	Non-volatile memory storage
Reference Data	32 KiSample maximum waveform size 32-bit resolution

Calculations

Table 16 – Calculations Specifications

Specification	Value
Calculate Channels	Quantity 4
Calculate Data	512 KiSample maximum waveform size 32-bit resolution
Calculate Functions	Add, Subtract, Multiply, Copy, Invert, Integral, Derivative, Absolute Value, Limit Test, Mask Test, Frequency Transform, Time Transform, Histogram, Measurement Trending
Limit Test	Measurement limit range testing or waveform mask testing
Limit Test Reporting	Measurement maximum, minimum, average, current value, pass count and fail count
Frequency Transform	FFT Magnitude
FFT Windowing	Rectangular, Hamming, Hann, Blackman, Flattop
FFT Data Format	Linear Magnitude, Logarithmic Magnitude, Phase, Real, Imaginary
Time Transform	Digital Infinite Impulse Response (IIR) filter
IIR Filter Type	Auto-generate: Low-pass, 2 to 40 data point smoothing
Histogram	65,536 bins for up to 16-bit histogram horizontal resolution
Measurement Trending	Historical waveform of measurement data. Provides trend data of 1 measurement point per capture.

Data Processing & Download

Table 17 – Data Processing & Download Specifications

Specification	Value
Self-Calibration	Automatic internal calibration: Input DC Offset Zero, Input DC Offset Adjust Scale Factor, ADC Balance, ADC Timing
Auto-Scale	Automatic adjust to input signals: Input Range, Offset, Sample Rate, Trigger Source and Trigger Level

Waveform Data Formats	16-bit or 32-bit signed integer 32-bit or 64-bit floating point Intel® or Motorola® Byte Order
Waveform Download Mode	
Normal	Every real-time data point
Decimated	Every N _{th} real-time data point (N = 2 to 100,000)
Interpolated	N points for every real-time point (N = 2 to 100)
Waveform Interpolation Modes	None, First Order (linear), or sin(x)/x (sinc)

Instrument Stored States

Table 18 – Instrument Stored States Specifications

Specification	Value
Functionality	Non-volatile storage of instrument setup configuration
Stored States	30 State 0 is Reset State Power-On State programmable

LED Indicators

Table 19 – LED Indicators Specifications

Specification	Value
RDY (Ready)	OFF: Hardware Failure ON: Unit has passed power-up self-diagnostics TOGGLE: Unit has an error pending in error queue
HST/LAN (Host)	OFF: Interface fault ON: Normal interface operation TOGGLE: Device identify enabled
TRG (Trigger)	OFF: Trigger event not detected ON/PULSE: Trigger complete event detected
ACT (Active)	OFF: Instrument Idle ON/PULSE: Data acquisition initiated
1588 (1588 Clock Status) (LXI only)	OFF: IEEE 1588 clock not synchronized or fault ON: Clock locked as IEEE 1588 slave TOGGLE @ 1 s: Clock synchronized as IEEE 1588 master TOGGLE @ 2 s: Clock synchronized as IEEE 1588 grand master
PWR (Power) (LXI only)	ON: Unit is powered on OFF: Unit is powered off

PXI Interface

Table 20 – PXI Interface Specifications

Specification	Value
PCI Bus Data Interface	33 MHz, 32 bit 132 MByte/s burst up to 120 MByte/s sustained
PCI Voltage	Universal, +3.3 V or +5 V
PCI Standard Compatibility	Version 2.2
PXI Slot Compatibility	PXI Standard Slot and PXIe Hybrid Slot Compatible
PXI Timing & Triggering Signals (XJ4 Connector)	PXI_TRIG[0:7] input/output PXI_STAR input PXI_CLK10 input
PXI Identification	
Primary ID	3712 (0x0E80)
Secondary ID	4400 (0x1130)

VXI Interface

Table 21 – VXI Interface Specifications

Specification	Value
Command Interface	A16 message-based servant, SCPI compatible
Interrupt Operation	Programmable interrupter, Level 1-7
Manufacturer ID	
Primary ID	3712 (0x0E80)
Secondary ID	440 (0x01B8)

LXI Interface

Table 22 – LXI Interface Specifications

Specification	Value
Command Interface	LAN 10/100/1000, SCPI Compatible
Manufacturer ID	
Primary ID	3712 (0x0E80)
Secondary ID	440 (0x01B8)

Status Reporting

Table 23 – Status Reporting Specifications

Specification	Value
IEEE-488.2 Device Status	Reporting Structure including Status Byte, Standard Event Registers, Questionable Registers, Operation Registers and Self-Test Status Registers

AC Power (LXI)

Table 24 – LXI AC Power Specifications

Specification	Value
Line Voltage	90-264 VAC, 47-63 Hz, automatic selection
Input Protection	AC line fuse, 250 VAC, 2.0 A, fast-acting
Harmonic Distortion	Meets EN610100-3-2
Surge Withstand	Meets EN61000-4
EMI Filtering	Meets CISPR 11 and 22 and FCC Part 15 Class B (conducted)

Power & Cooling Specifications

Power Supplies

Table 25 – Power Supplies Specifications

Model	Platform	Voltage	Typical Current	Maximum Current
ZT4441	PXI	+3.3 VDC	3.37 A	4.19 A
		+5 VDC	1.23 A	1.80 A
		+12 VDC	0.02 A	0.02 A
		-12 VDC	0.01 A	0.01 A
	VXI	+5 VDC	3.96 A	5.33 A
		+12 VDC	0.02 A	0.02 A
		+24 VDC	0.00 A	0.00 A
		-2 VDC	0.07 A	0.08 A
		-5.2 VDC	0.32 A	0.36 A
		-12 VDC	0.01 A	0.01 A
		-24 VDC	0.00 A	0.00 A
	LXI	115 VAC	0.34 A	0.42 A

ZT4442	VXI	+5 VDC	6.47 A	8.50 A
		+12 VDC	0.05 A	0.05 A
		+24 VDC	0.00 A	0.00 A
		-2 VDC	0.07 A	0.08 A
		-5.2 VDC	0.49 A	0.57 A
		-12 VDC	0.02 A	0.02 A
		-24 VDC	0.00 A	0.00 A
	LXI	115 VAC	0.46 A	0.54 A

Total Cooling and Power Consumption

Table 26 – Cooling and Power Consumptions Specifications

Model	Platform	Typical Cooling & Power	Maximum Cooling & Power
ZT4441	PXI	17.6 W	23.2 W
	VXI	21.9 W	29.0 W
	LXI	39.0 W	48.4 W
ZT4442	VXI	35.7 W	44.4 W
	LXI	53.2 W	62.6 W

Physical & Environmental Specifications

Size & Weight

Table 27 – Size & Weight Specifications

Specification	Value
PXI Physical Size	Single-Wide 3U PXI Instrument 8.25" x 0.79" x 5.25" (L x W x H) 20.96 cm x 2.01 cm x 13.34 cm (L x W x H)
VXI Physical Size	Single-Wide C-size VXI bus Instrument 14.45" x 1.20" x 10.35" (L x W x H) 36.70 cm x 3.05 cm x 26.29 cm (L x W x H)
LXI Physical Size	Half-Width 1U LXI Instrument 13.35" x 7.25" x 1.75" (L x W x H) 33.91 cm x 18.42 cm x 4.345 cm (L x W x H)
PXI Weight	12.3 oz 349 g
VXI Weight	
ZT4441	2.82 lbs or 1.28 kg
ZT4442	3.11 lbs or 1.41 kg
LXI Weight	

ZT4441	4.48 lbs or 2.03 kg
ZT4442	4.77 lbs or 2.16 kg

Temperature Range

Table 28 – Temperature Range Specifications

Specification	Value
Operating	0°C to +50°C ambient
Storage	-40°C to +75°C
Over-Temperature	Automatic shutdown if internal temperature exceeds +70°C
Calibration Range	+20°C to +30°C ambient, after a 20 minute warm-up period, to meet all calibration specification accuracies

Relative Humidity

Table 29 – Relative Humidity Specifications

Specification	Value
Operating or Storage	10% to 90% non-condensing, up to +40°C

Altitude

Table 30 – Altitude Specifications

Specification	Value
Operating	Up to 3 km Up to 5 km with Maximum Input (1 MΩ) of ± 100 V
Storage	Up to 15 km

Safety & Compliance Information

Safety

This product is designed to meet the requirements of the following standard of safety for electrical equipment for measurement, control, and laboratory use:

- EN 61010-1

Electromagnetic Compatibility

CE Marketing EN 61326-1:1997 with A1:1998 and A2:2001 Compliant.

FCC Part 15 (Class A) Compliant.

Emissions

- EN 55011 Radiated Emissions, ISM Group 1, Class A, distance 10 m, emissions < 1 GHz
- EN 55011 Conducted Emissions, Class A, emissions < 10 MHz Immunity
- EN 61000-4-2 Electrostatic Discharge (ESD), 4 kV by Contact, 8 kV by Air
- EN 61000-4-3 RF Radiated Susceptibility, 10 V/m
- EN 61000-4-4 Electrical Fast Transient Burst (EFTB), 2 kV AC Power Lines
- EN 61000-4-5 Surge
- EN 61000-4-6 Conducted Immunity
- EN 61000-4-8 Power Frequency Magnetic Field, 30 A/m
- EN 61000-4-11 Voltage Dips and Interrupts

CE Compliance

This product meets the necessary requirements of applicable European Directives for CE Marking as follows:

- 72/23/EEC Low Voltage Directive (Safety)
- 89/336/EEC Electromagnetic Compatibility Directive (EMC)

See Declaration of Conformity for this product for additional regulatory compliance information.

LXI Conformance

This product's LXI models are conformant to the LXI Consortium's Functional Class C.



Teradyne, Inc. 600 Riverpark Drive, North Reading, MA 01864
+1.978.370.2700 | www.teradyne.com