

TestStation Site Preparation Guide

**for
TestStation 12X
and
TestStation LX**



**TestStation
Site Preparation
for
TestStation 12X
and
TestStation LX**

Copyright © Teradyne, Inc. 2004. All rights reserved under copyright laws of the United States and other countries. The technical data included herein, excluding computer software documentation, is subject to the LIMITED RIGHTS as set forth in FAR 52.227-15 (JUN 1987) and DFARS 252.227-7015 (JUN 1995). All technical data and computer software documentation contained herein is proprietary and confidential to Teradyne, Inc. or its licensor. All computer software documentation contained herein is Commercial Computer Software Documentation, proprietary to Teradyne, Inc. or its licensor and furnished under limited license only. For solicitations issued by the United States, its agencies or instrumentalities (the "Government") on or after December 1, 1995 and the Department of Defense ("DoD") on or after September 29, 1995, the only rights provided in the Commercial Computer Software Documentation shall be those specified in a license customarily provided to the public by Teradyne, Inc. in accordance with FAR 12.212(a) and (b) (OCT 1995) or DFARS 227.7202-3(a) (JUN 1995). For solicitations issued before December 1, 1995 by the Government (other than DoD) use, duplication or disclosure of the documentation shall be subject to the RESTRICTED RIGHTS as set forth in subparagraph (c)(1) and (2) of the commercial computer software - restricted rights clause at FAR 52.227-19 (JUN 1987). For solicitations issued before September 29, 1995 by DoD: RESTRICTED RIGHTS LEGEND - The use, duplication, or disclosure by the Government is subject to restrictions as set forth in subparagraph (c)(1)(ii) of the Rights in Technical Data and Computer Software clause at DFARS 252.227-7013 (OCT 1988).

The following are trademarks or registered trademarks of Teradyne, Inc.

Access Analyzer™	DBIU™	GR 228X™	Orient Xpress™	Teradyne & Des.™
Ai-7 Series™	Defect Display Station	GR & Des.™	Panel-Test™	TestAdvisor™
Alchemist™	(DDS)™	GR AccelerATE®	PinPoint™	TestStudio™
APC™	DeltaScan™	GR Advise™	PRISM™	Test Toolbox™
Argo™	Diamon™	GR Navigate™	Production Solutions	TEST XPRESS™
ATG XPRESS™	DigiBridge™	GRNet™	International™	TestLink™
AutoChecker™	DRMU™	GR Producibility Analyzer™	Process Quality Manager™	Testnet™
Autogen™	EJB-Tester™	GR Stinger™	ProcessWatch™	TPS Converter Studio™
AutoLoad™	EJB-Monitor™	GR SwitchManager™	ProgramGuide™	TRACS™
Autopub™	EJB-Load™	GR TestManager™	Program Xplorer™	Vector Bus™
Autotune™	EJB-TestSuite™	GR TestStation™	PromptTest™	Vector Performance (VP)™
BasicSCAN™	EKB-Test™	GR TestStation 12X™	PXIscan™	VICTORY™
Bi4-Series™	E-MANAGER™	GR TestStation TSM™	Quick-Check™	Virtual In-Circuit Test
Bi-420™	E-SENTINEL™	GR Versa™	QuickScan™	(VICT)™
Boundary In-Circuit Test (BICT)™	ENCOMPASS™	GR Versa OT™	RCU™	Virtual Component and
	FAST™	GR Xpert™	RMU™	Cluster Test (VCCT)™
Boundary Scan Intelligent	FrameScan™	GR X-Station 2D™	SAC™	VRS™
Diagnostics (BSID)™	FrameScan Plus™	GR X-Station 3-D™	Safecracker™	VXIscan®
BusBust™	GENEVA®	GridScan™	SafeTest™	WaveScan™
BusScan™	GenRad®	Inline Device Programmer (ILD)™	Scan Pathfinder™	XFrame™
Call Sentinel™	GenRad CAT System™	InterScan™	Scavenger™	XLT™
Cap Xpress™	GR®	Isolution™	Scot™	Xpress Model™
CapScan™	GR-X90™	JUDGE™	ScratchProbe™	Xpress Start™
CASTOR™	GR-X130™	JUNCTION Xpress™	SierraMate™	Xpress Train™
CatSystem™	GR-X130L™	LASAR™	SIMUL™	Xpress Transfer™
CCU™	GR-X160L™	L-Series™	Softbridge™	Xpress Yield™
Configural Recognition™	GR-X1002™	L200-Series™	Softbridge & Des.™	XStation™
CMU™	GR-X1500™	L300-Series™	SoftProbe™	XStation Combo™
Cshell™	GR-X1510™	Lightning™	Spectrum™	XStation HS™
Component Designer (CDES)™	GR-X1525™	M9-Series™	Spectrum 8800-Series™	Z1800VP™
D2B™	GR-X1550™	MicroModal™	SpeedPlus™	Z1800-Series™
Design-to-Build™	GR-X4005™	Momentum™	Stinger™	Z1820VP™
D2B Alchemist™	GR-X4010™	MultiScan™	Stronghold™	Z1840VP™
D2B DesignView™	GR-X4011™	MultiScan II™	Syncload™	Z1850VP™
D2B ECO™	GR-X7005™	Multi-Tester plus™	The Technology of Knowledge®	Z1880VP™
D2B Strategist™	GR-X7010™	NIM™	Teradyne®	Z1890VP™
D2B DFx™	GR2000™	NXR™	Teradyne®	
D-TRACKER™	GR4000™	Opens Xpress™	TeraNet™	
	GR5000™			

Product names listed are trademarks of their respective manufacturers. Company names listed are trademarks or trade names of their respective companies.

The material in this manual is for informational purposes only and is subject to change, without notice. Teradyne assumes no responsibility for any error or for consequential damages that may result from the use or misinterpretation of any of the procedures in this publication.

WARNINGS

- Do not remove covers. Potentially lethal voltages are present inside the system. Observe all WARNING markings on the equipment and WARNING notices in the manual. If servicing is necessary, it should be performed only by a qualified person familiar with the electrical shock hazards present inside the system.
- Grounding circuit continuity is vital for safe operation of the equipment. Never operate equipment with grounding conductor disconnected.
- Safeguard your hands and fingers while handling any fixture or other accessory. Be sure it is securely supported if you reach under it. If it is heavy, you must have another person help to move it.
- The symbol  IEC417 on equipment signifies that the manual contains information to prevent injury or equipment damage. Observe and heed all WARNING notices in the manuals and the equipment. WARNINGS call attention to personnel safety information.
- Replace any fuse only with the same type and ratings as labeled on the equipment and/or listed in the manual.

MISES EN GARDE

- Ne pas enlever les couvercles. Les niveaux de tension se trouvant dans le système sont extrêmement dangereux. Respectez toutes les consignes de sécurité figurant sur l'équipement et les MISES EN GARDE données dans ce manuel. Seule une personne qualifiée, connaissant les risques de décharge électrique du système, est autorisée à effectuer les opérations de nettoyage ou de réparation du système.
- Le circuit doit être mis à la terre sans discontinuation pour garantir un fonctionnement sans danger de l'équipement. Ne jamais faire fonctionner l'équipement pendant que le raccord à la terre est déconnecté.
- Protégez-vous les mains et les doigts pendant le maniement de tout dispositif de serrage ou autre accessoire. Assurez-vous que ceux-ci soient bien solidement fixés en place, avant de vous pencher sous eux. Si l'accessoire en question est trop lourd, faites-vous aider pour le déplacer.
- Le symbole  IEC417 figurant sur l'équipement signifie que le manuel contient des informations permettant d'empêcher les accidents ou l'endommagement de l'équipement. Respectez toutes les consignes de MISES EN GARDE données dans le manuel et figurant sur l'équipement. Les MISES EN GARDE attirent l'attention sur la nécessité de se protéger.
- Ne remplacez les fusibles qu'avec des fusibles du même type et de la même valeur que ceux mentionnés sur l'équipement et figurant dans le manuel.

WARNHINWEISE

- Abdeckungen nicht entfernen. Potentiell lebensgefährliche Spannungsbedingungen innerhalb des Systems vorhanden. Alle auf der Einrichtung befindlichen WARNMARKIERUNGEN und im Handbuch enthaltenen WARNHINWEISE beachten. Wartungsarbeiten dem qualifizierten Personal überlassen, das mit den innerhalb des Systems vorhandenen Gefahren eines elektrischen Schlags vertraut ist.
- Die Erdung des Schaltungsdurchgangs ist eine Grundvoraussetzung für den sicheren Betrieb der Einrichtung. Einrichtung niemals ohne Erdleiter betreiben.
- Hände und Finger bei der Handhabung einer Spannvorrichtung oder eines anderen Zubehörteils schützen. Sich vor der Platzierung der Hände unterhalb der Einrichtung vergewissern, daß die Einrichtung über ausreichenden Halt verfügt. Falls die Einrichtung schwer ist, sich von einer anderen Person beim Tragen helfen lassen.
- Das auf der Einrichtung befindliche Symbol  IEC417 bedeutet, daß das Handbuch Informationen zur Verhinderung von Körperverletzungen oder Sachschäden enthält. Alle in den Handbüchern enthaltenen und auf der Einrichtung befindlichen WARNHINWEISE beachten und befolgen. WARNHINWEISE sollen auf Informationen zur persönlichen Sicherheit aufmerksam machen.
- Sicherungen nur durch Sicherungen des gleichen Typs und der gleichen Nennleistung ersetzen. Auf der Einrichtung befindliche Etiketten und im Handbuch enthaltene Informationen zu Rate ziehen.

AVISOS

- Não remova as tampas. Há voltagens potencialmente fatais presentes na parte interna do sistema. Observe todas as marcações de AVISOS no equipamento e descrições de AVISOS no manual. Se for necessário fazer manutenção, esta deve ser feita somente por uma pessoa qualificada familiarizada com os perigos de choques elétricos presentes na parte interna do sistema.
- A continuidade do circuito de aterramento é vital para a operação segura do equipamento. Nunca opere o equipamento com o cabo de aterramento desligado.
- Proteja as suas mãos e dedos ao operar qualquer dispositivo ou outro acessório. Certifique-se que ele esteja suportado com segurança se você tiver que alcançar algo debaixo dele. Se for pesado, você deve ter a ajuda de uma outra pessoa para movê-lo.
- O símbolo  IEC417 no equipamento significa que o manual contém informações para prevenir ferimentos ou danos ao equipamento. Observe e preste atenção a todos os AVISOS nos manuais e no equipamento. Os AVISOS chamam a atenção a informações sobre a segurança pessoal.
- Substitua qualquer fusível somente com um do mesmo tipo e da mesma capacidade nominal como marcado no equipamento e listado no manual.

ADVERTENCIAS

- No quitar las tapas. En el interno del sistema hay voltajes potencialmente mortales. Obsérvense todos los rótulos de ADVERTENCIA presentes en el equipo, así como la descripción de las notas de ADVERTENCIA presentadas en el manual. De ser necesario, el servicio de mantenimiento deberá ser efectuado únicamente por personal calificado que esté familiarizado con los peligros de choque eléctrico presentes en el sistema.
- La continuidad del circuito de puesta a tierra es de vital importancia para el funcionamiento seguro del equipo. Nunca se debe usar el equipo con el conductor de puesta a tierra desconectado.
- Protéjanse las manos y los dedos toda vez que sea necesario manipular un dispositivo u accesorio. Cerciorarse de que el mismo esté firmemente sujetado antes de proceder a trabajar debajo de él. Si el aparato u accesorio fuera pesado, pedir la ayuda de otra persona para moverlo.
- El símbolo  IEC417 que aparece en el equipo significa que el manual contiene informaciones para evitar lesiones personales o daños al equipo. Obsérvense y préstese atención a toda las notas de ADVERTENCIA presentes en los manuales y en el equipo. Las ADVERTENCIAS sirven para llamar la atención sobre informaciones de seguridad para el personal.
- Reemplazar los fusibles únicamente con otros del mismo tipo y capacidad, según lo indique el rótulo en el equipo y la descripción en el manual.

CAUTIONS

- Observe and heed all CAUTION notices in the manuals and on the equipment. CAUTIONS call attention to information about safeguarding *equipment* from damage.



HANDLING PRECAUTIONS FOR ELECTRONIC DEVICES SUBJECT TO DAMAGE BY STATIC ELECTRICITY

Place instrument or module to be serviced, spare parts in conductive (anti-static) envelopes or carriers, hand tools etc. on a work surface defined as follows. The work surface must be conductive and reliably connected to earth ground through a safety resistance of approximately 250 kilohms. The surface must **NOT** be metal. (A resistivity of 30 to 300 kilohms per square inch is suggested.) Avoid placing tools or electrical parts on insulators.

Ground the frame of any line-powered equipment, test instruments, lamps, soldering irons, etc., directly to earth ground. To avoid shorting out the safety resistance, be sure that grounded equipment has rubber feet or other means of insulation from the work surface. The module being serviced should be insulated while grounded through the power-cord ground wire, but must be connected to the work surface before, during and after any disassembly or other procedure in which the line cord is disconnected.

Exclude any hand tools (such as non-conductive plunger-type solder suckers) that can generate a static charge.

Ground yourself reliably, through a resistance, to the work surface; use, for example, a conductive strap or cable with a wrist cuff. The cuff must make electrical contact directly with your skin; do **NOT** wear it over clothing. (Resistance between skin contact and work surface through a commercially available personnel grounding device is typically 250 kilohms to 1 megohm.)

If any circuit or IC packages are to be stored or transported, enclose them in conductive envelopes or carriers. Remove them only with the above precautions; handle IC packages without touching the contact pins.

Avoid circumstances that are likely to produce static charges, such as wearing clothes of synthetic material, sitting on a plastic-covered stool (particularly while wearing wool), combing your hair, or making extensive erasures. *These circumstances are most significant when the air is dry.*

When testing static sensitive devices, be sure DC power is on before, during, and after application of test signals. Be sure all pertinent voltages have been switched off while boards or components are removed or inserted.

Contents

Using This Manual

Overview	vii
Audience	vii
Document Conventions	viii
Technical Support Center	ix
How To Order Additional Documentation	x
Patent Information	x

Site Preparation Overview

Site Planning Before System Delivery	1 - 1
Site Planning Requirements	1 - 2
Space Requirements	1 - 2
Weight Requirements	1 - 2
Environmental Requirements	1 - 2
Power Requirements	1 - 2
Vacuum Requirements	1 - 2
Compressed Air Requirements	1 - 3
Cooling Requirements	1 - 3
Delivery Routing	1 - 3

System Requirements

Space and Weight Requirements	2 - 1
Vacuum Pump Location	2 - 6
Environment Requirements	2 - 7
System	2 - 7
Personal Computer	2 - 7
System Input Power Requirements	2 - 8
208/120 VAC Input Power Configuration Range	2 - 9
220-240 VAC input Power Configuration Range	2 - 10
Vacuum Pump (Option) Input Power Requirements	2 - 12
Vacuum Requirement	2 - 12
Compressed Air Requirement	2 - 13
Cooling Requirement	2 - 13
Test Fixture Procurement	2 - 13

Receiver Sizes2 - 13
Adapter Types2 - 14
Ethernet Requirement2 - 14

Safety Considerations in Site Planning

Introduction3 - 1
System Grounding3 - 1
Fire Precautions3 - 1
Personnel Safety Considerations3 - 1

Additional Site Requirements

Vacuum Pump4 - 1
 Vacuum Pump Hookup Kit4 - 1
 Obtaining Longer Vacuum Hose Assemblies4 - 2
 Oil4 - 2
Compressed Air Hose Kits4 - 2
 Compressed Air Hose Kit4 - 2
 Compressed Air Hose Extension Kit4 - 3
Modem Requirements4 - 4
Fixture Storage4 - 4
Circuit-Board Storage Racks4 - 4
Telephone Installation4 - 4
Recommended Supplies4 - 5
 Printer Paper4 - 5
 PC Floppy Drive Diskette4 - 5
 CD ROM Drive CDs4 - 5
 System Air Filter Kit4 - 5
Additional Suggested Site Considerations4 - 5

Site Preparation Checklist

Introduction A - 1

Using This Manual

Overview





This document describes the information to consider before installing or moving a TestStation system, or before adding optional equipment to the system. Safety and efficiency considerations related to site selection, preparation and management are also described. This guide enables you to prepare a site for your system that permit the system to function in a safe, reliable and efficient manner, while enabling personnel to work in a comfortable and safe environment. After installation, keep with other system documentation. See this guide when any changes to the configuration or site are contemplated.

Audience

This document should be read by all personnel with responsibility for site selection, preparation, and management of the system.

Document Conventions

The following document conventions are used throughout the documentation set.

Convention	Indicates
Bold monospace text	command text that you enter
Bold text	commands, keys, buttons, prompts, menu options, icons, and literals within text
Courier text	command, syntax, or error message
<i>Italic monospace text</i>	replace the <i>term</i> with a valid entry
<i>Italic text</i>	manual title, chapter title, or section title
P/N or PN	part number
[<i>text, text</i>]	field within the brackets is optional
{ <i>text, text</i> }	select one or more choices within the braces
CAUTION	potential harm to the system or equipment as a result of this action
 Example	the beginning of an example
 End Example	the end of an example
 NOTE	specialized information that may benefit you
 NEXT	informational options that direct you to the next chapter or step
 WARNING	potential harm to you as a result of this action
... and :	the omission of undetermined information

Technical Support Center

You can contact the Technical Support Center for assistance at any time if you are unable to solve a problem through the use of online Help or product documentation.

Before contacting the Technical Support Center, please have the following information available:

- Your customer number
- Hardware system type
- System serial number
- Software version number

You can contact the Technical Support Center using the information below.

Phone	Worldwide Support Line 1-800-TERADYNE (1-800-837-2396)
Fax	(978) 370-6260
E-mail	cs1@teradyne.com
Mail	Teradyne, Inc. Assembly Test Division 600 Riverpark Drive North Reading, MA 01864
World Wide Web	http://www.teradyne.com Under Products, click the <i>Assembly Test</i> link.
eKnowledge Web	Under Customer Support, click the <i>eKnowledge > Assembly Test</i> link. Teradyne's product support website offers customers 24/7 access to product manuals, software patches and updates, emergency license keys, application notes, technical literature, IC modules, and on-line incident management.

How To Order Additional Documentation

To reorder this manual or any others, contact Technical Support.

Worldwide Support Line
1-800-TERADYNE (1-800-837-2396)

Part Number

034-352-01

Patent Information

The Teradyne software, firmware and test systems described in this manual are protected under one or more of the following US patent numbers, as well as other US patent applications and corresponding foreign patents and patent applications.

4070565	4856001	5172377	5594770	6138143
4216539	4857833	5321701	5596587	6163160
4247817	4864219	5359237	5602490	6175230
4459693	4884024	5391993	5615219	6194910
4500993	4901315	5414715	5631572	6363217
4521902	4931742	5457380	5682392	6363507
4536239	4977370	5471310	5727021	6449744
4620304	5020086	5486753	5736862	6463426
4660197	5057775	5491737	5748672	6507920
4686391	5060288	5500886	5786697	6549660
4688241	5101150	5506510	5811980	6563352
4734637	5103109	5521513	5861743	6618629
4791356	5111406	5541856	5963670	6622272
4791359	5124636	5548525	6052809	6748046
4809308	5124638	5554928	6114848	RE31828
4835379	5127009	5578930	6128759	RE35423

Chapter 1

Site Preparation Overview

Site Planning Before System Delivery

Proper site planning before receiving your system is the key to a smooth installation as well as efficient production flow during operation. Major considerations include space, weight, environmental, power, vacuum, compressed air, and cooling requirements, as well as delivery routing. Figure 1-1 shows a representation of the system. If you require site planning assistance, contact the Teradyne Technical Support Center. See *Using This Manual* for more information about contacting the Teradyne Technical Support Center.

Figure 1-1 TestStation Test Systems



Site Planning Requirements

The following sections provide an overview of the requirements related to the site planning process.

Space Requirements

Provide adequate space for the placement and servicing of the system and peripherals. In addition, consider space requirements for operating personnel, tables, chairs, and storage areas (for test fixtures, paper, etc) and sufficient space for adequate ventilation of the system components. See Chapter 2.

Weight Requirements

System weight, as well as the weight of peripheral equipment and other items positioned in the same general area, must be considered. The floor loading capacity must be sufficient to support the weight involved. Most industrial plant floors support weights of 50 psf (2.4 kPa) or more, which is normally adequate for this type of equipment. If you have a question as to whether the floor loading capacity or structural considerations are adequate, consult a qualified structural engineer prior to delivery. See Chapter 2.

Environmental Requirements

A room with an air distribution system that provides cool, well-filtered humidified air is ideal for this system. Air pressure within the room should be maintained at a higher level than the air pressure of adjacent areas to prevent dust infiltration. While this system does not require an absolute clean-room environment, cleanliness and freedom from excessive heat and dust should always be a prime consideration to reduce the possibility of equipment failure caused by heat and dust build-up. Maintain the temperature and humidity specifications for the system and its peripheral equipment within safe operating levels at all times. See Chapter 2.

Power Requirements

Provide input power and grounding requirements prior to system installation. Sufficient AC power must be available for all equipment. A separate earth safety ground connection is also required for this system. Electrical conduit is not considered an acceptable separate earth ground path; however, water pipes or other known good earth ground paths may sometimes be used. Locate fuse or circuit-breaker-protected AC outlets and safety ground connections as close to the system as possible in order to keep cable runs short. See Chapter 2.

Vacuum Requirements

Vacuum is required for system operation. Vacuum serves two functions: it mates the test fixture with the system's receiver and mates the unit-under-test to the test fixture. The customer is responsible for providing and connecting AC input power to the vacuum pump motor and connecting the vacuum fittings from the pump to the system's vacuum port on the rear of the power bay. See Chapter 2 and Chapter 4.

Compressed Air Requirements

The customer is responsible for providing a compressed air source that is required for system operation. The customer is responsible for providing and connecting the compressed air hose fittings from the site's compressed air source to the system's compressed air port on the rear of the pin cage. See Chapter 2 and Chapter 4.

Cooling Requirements

The site cooling plant must be able to compensate for the heat produced when the system is in operation. The heat produced by the system, and any attached peripherals, is computed based upon the amount of current required by the system and its peripherals. See Chapter 2.

Delivery Routing

Prior to the system's delivery, determine the route that the system crates will travel from the receiving area to the installation site. Develop a routing plan to cope with such problems as bends or obstructions in hallways, elevator size, and weight limitations. Advance planning to eliminate obstructions along the delivery route can save valuable time during installation.

Teradyne recommends that the crated system be moved from your receiving area to the system's installation site (See Table 2-1 for dimensions). Standard practice is that Teradyne's installer uncrates the system at its installation site. You must provide a minimum distance of 12 ft (3.66 m) to the right side of the fork lift entry for uncrating space at the installation site.

Chapter 2

System Requirements

This chapter describes the space and weight, environmental, input power, and cooling requirements in addition to site considerations for peripheral equipment and test fixture procurement.

Space and Weight Requirements

The shipping information in Table 2-1 is for the crated system and optional equipment. For space planning purposes, Table 2-2 lists the uncrated dimensions and weight for the system and optional peripheral equipment. Figure 2-1 shows system space requirements.

When planning space requirements for the system and its optional peripherals:

- Allow sufficient room around the system and its peripherals for access by operation and service personnel. Sufficient room is considered 40 in. (101.6 cm) between each side of the system and the nearest wall or any other obstacle.
- If systems are located adjacent to each other, make certain that proper air space separates them to prevent the exhaust air of one system from being drawn into the other system.
- Do not block the air vents that are located on the front, back and sides of the system. The minimum distance anything should be from the air vents is 12 in.

Table 2-1 Crated System Dimensions and Weight

Item	Dimensions (width x height x depth)	Weight	
		kg	lb
Crated System (with peripherals and various cartons)	73 x 80 x 69 in (185.4 x 203.2 x 175.3 cm)	636.4	1400
Optional Equipment - Vacuum Pump	22 x 33 x 22 in. (55.9 x 83.8 x 55.9 cm)	68.0	150.0

Table 2-2 Uncrated System Dimensions and Weight

System	Dimensions (width x height x depth)	Weight	
		kg	lb
Horizontal Configuration	66.00 x 33.25 x 44.50 in. (167.25 x 84.45 x 113.0 cm)	481	1060
Optional Peripheral Equipment			
Seiko Model DPU-5347	7.5 x 8.8 x 5.5 in.	2.2	4.4
Strip Printer	(19.1 x 22.4 x 14 cm)		
Okidata Microline 320	15.7 x 4.6 x 13.6 in.	7.3	16.0
Line Printer	(39.9 x 11.7 x 34.5 cm)		
Vacuum Pump	16.8 x 17 x 28.6 in. (42.7 x 43.2 x 72.5 cm)	56.0	123.0

† Depth with keyboard tray extended is 60.00 in. (152.4 cm)

Figure 2-1 TestStation System Space Requirements (Top View)

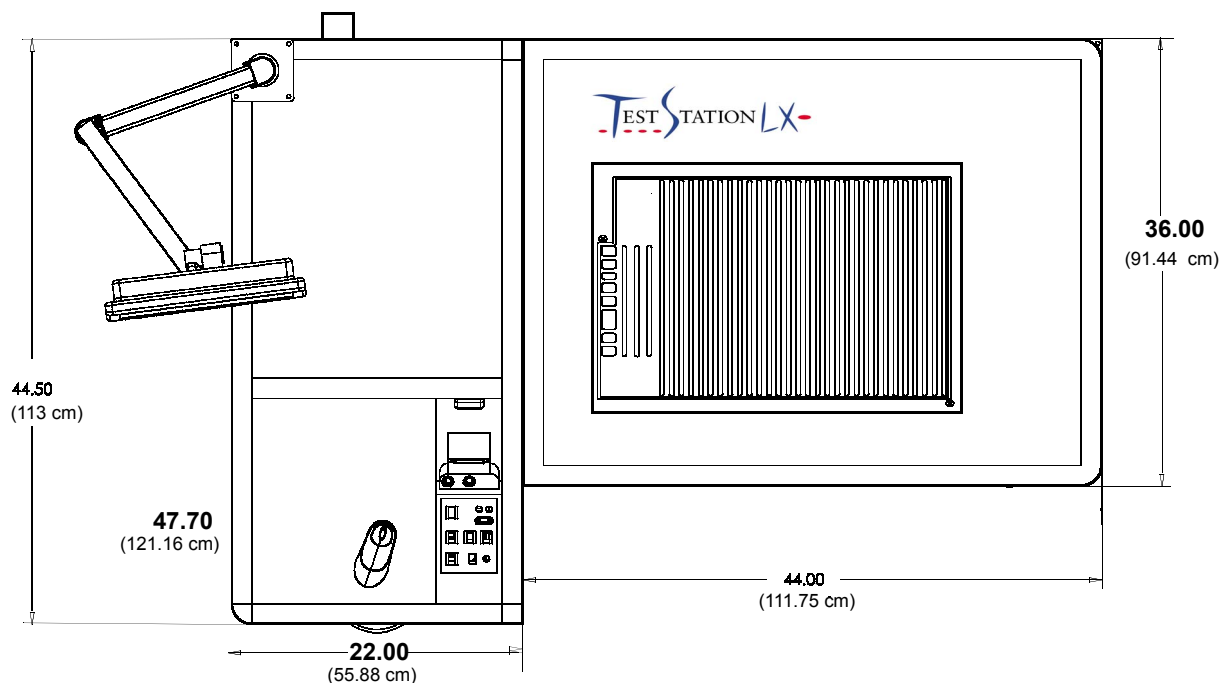

Figure 2-2 TestStation System (Right Side View)

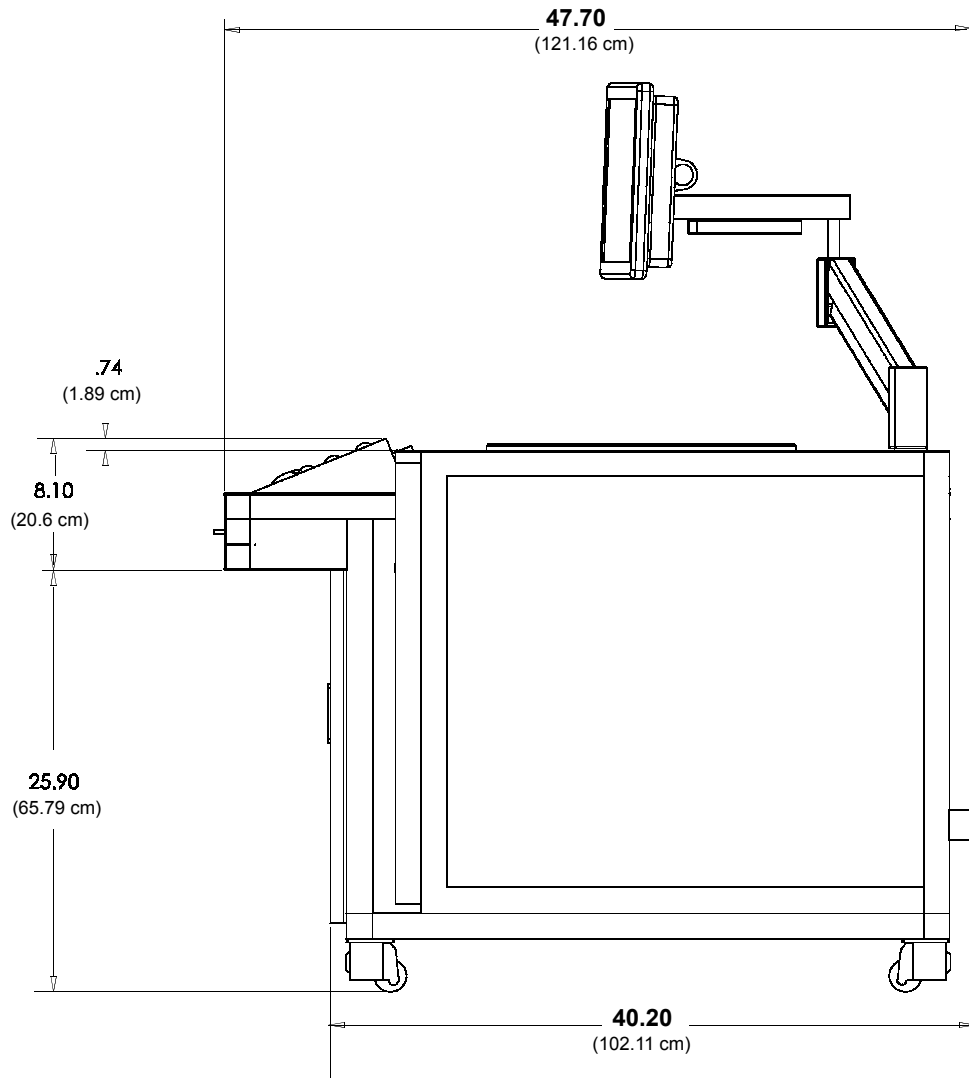

Figure 2-3 TestStation System (Right Side View Tilted)

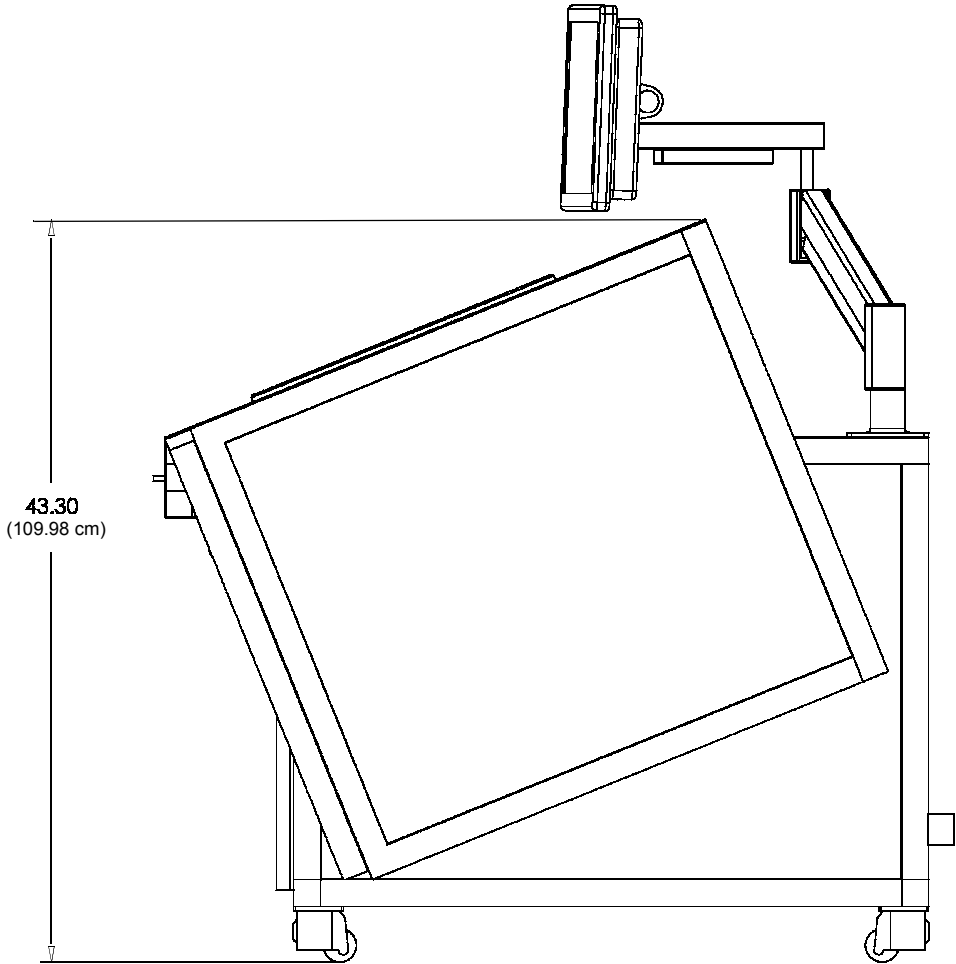

Figure 2-4 TestStation System (Front View)

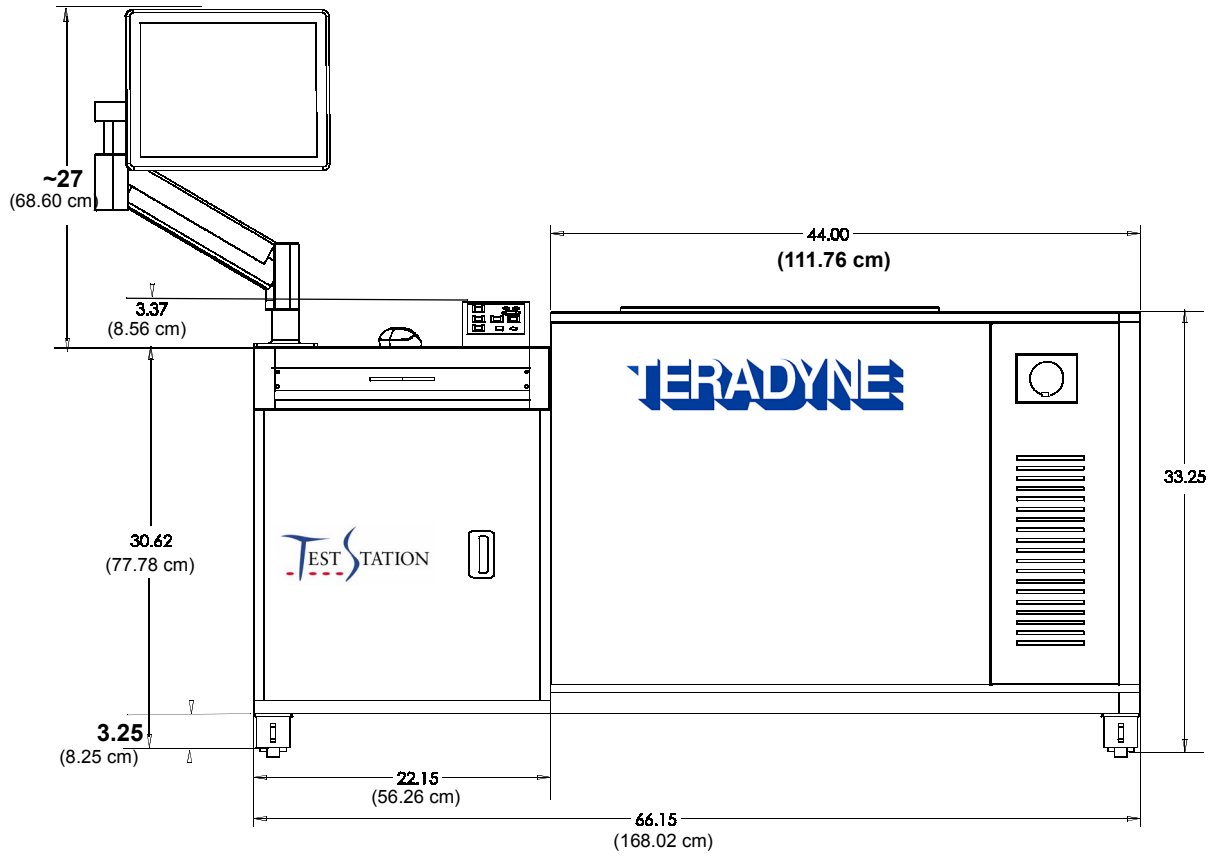
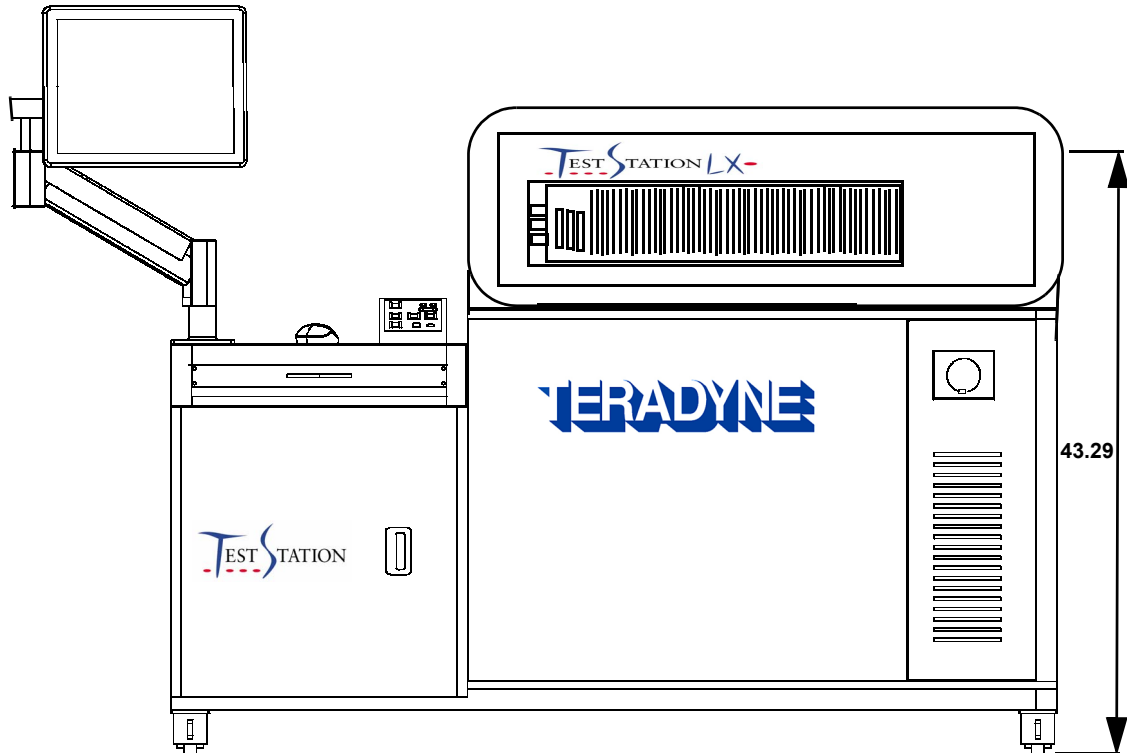

Figure 2-5 TestStation System (Front View Tilted)



Vacuum Pump Location

Install the Busch pump in a horizontal position on a level surface so that it is evenly supported on its feet. Allow at least 1 ft (30.5 cm) of air space between the pump and any walls or other obstructions for the flow of cooling air.

Also, provide access space for:

- Viewing the oil-sight glass (located on the lower side of the pump).
- Maintaining the vacuum pump (adding/changing oil and filter replacement). It is recommended that the pump's exhaust be vented outside of the building.

Environment Requirements

These operating and storage environmental limits apply to the entire system including its equipment options when they operate as part of the system. Manufacturers of peripheral equipment may list operational temperature and humidity ranges that exceed the system limits shown in the following sections.

System

The system operating and storage environmental limits are:

Limit	Operating Environment	Storage Environment †
Relative Humidity	20 to 80% non-condensing	Up to 95% non-condensing
Ambient Temperature ††	59 to 95°F (15 to 35°C)	-40 to +151°F (-40 to 66°C)
Maximum Temperature Gradient	18°F/hour (10°C/hr)	18°F/hour (10°C/hour)
Maximum Humidity Gradient	10%/hr	10%/hr
Maximum Wet Bulb Temperature	77°F (25°C)	115°F (46°C)
Minimum Dew Point Temperature	36°F (2°C)	36°F (2°C)
Altitude	-3000 ft to 10,000 ft (-900 m to 3000 m)	-5000 ft to 50,000 ft (-1500 m to 1500 m)

† (Up to Three Months)

†† Maximum temperature reduced by 1°F/1000 ft (1.8°C/1000 m) elevation.

Personal Computer

The following operating and storage environmental limits are applicable to the personal computer.

Limit	Operating Environment	Storage Environment
Temperature	50 to 95°F (10 to 35°C)	-40 to 149°F (-40 to 65°C)
Relative Humidity	8 to 80% non-condensing	80% non-condensing
Altitude	-50 (-12.2m) to 10,000 ft (3048 m)	-50 (-12.2m) to 35,000 ft (10668 m)

System Input Power Requirements



WARNING: To avoid shock hazard, the system must be operated with an adequate earth ground. See Chapter 3.

Wiring must conform to country and local electrical codes.



Note: This product is intended for installation in accordance to IEC 664, Installation Category II. This category indicates that this product is designed for use at the local level and refers to the local power distribution within your building.

The requirements for the plug, power cord, and the maximum loads allowable on a branch circuit for cord and plug utilization equipment vary on a country-to-country basis. Install the system in accordance with all applicable codes for the system voltage configuration and installation location.

The AC input power source (and receptacle) for the system must be installed by the customer prior to system installation. Make certain that the receptacle connector that accepts the system's plug meets the system's voltage and current requirements. It is the customer's responsibility to procure and install the mating receptacle. The International Configurations¹ series of plug/receptacle connectors (specified in the following power configurations) comply with most country and local electrical codes.

The primary AC power source to the system must be a clean line. There should be no abnormal power-line disturbances such as transient spikes; dropped cycles; large voltage or frequency fluctuations; current surges; or voltage, phase angle, or interphase voltage imbalances.

It is the customer's responsibility to convert the building power source, if required, to the system's input power requirement. Also, the customer must procure and install any power conversion and conditioning equipment prior to system installation.

You can order the system in the low voltage or high voltage AC input power configuration with a frequency of 50 or 60 Hz. If your system needs to be converted from one of these power configurations to the other, contact Teradyne's Technical Service Center.

Low Voltage Configuration (only for US and Canada installations)	High Voltage Configuration (only for non-US and non-Canada installations)
208/120 V, 3 Phase Wye (4 wires plus ground)	380-415 V/220-240 V, 3 Phase Wye (4 wires plus ground)
50 A Service per Phase Required (system rated 42 A per phase)	32 A Service per Phase Required (system rated 29 A per phase)



Note: Figure 2-6 shows the complete AC power cord with connectors. Use this figure to reference the the proper location of the AC connection components.

¹. International Configurations, Inc. Box 3374 Enfield CT 06083 Tel. 860 749-6380 Fax 860 749-2985

Figure 2-6 AC Connection Components

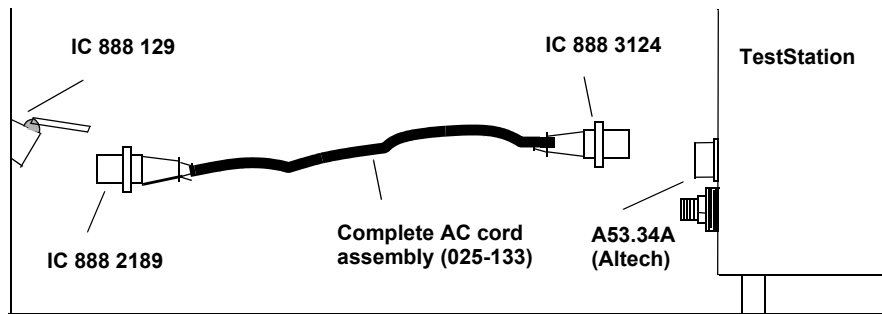

208/120 VAC Input Power Configuration Range

For this configuration, the system requires 3-phase input power service of 208/120 VAC wye connected, 4-wire plus safety ground, 50/60 Hz, 50 A per phase. The test system is supplied with a 12 ft (3.7 m) power cable terminated with an International Configuration* (IC) 888-2189 or equivalent 4-pole, 5-wire grounding plug at the user's end and an IC connector 888-3124 or equivalent (See Figure 2-6) at the tester end. Figure 2-7 illustrates the 120v Phase-to-Neutral Wye input wiring for the user wall receptacle (IC 888-129 or equivalent) which is to be procured and installed by the customer prior to delivery of the system. Figure 2-9 illustrates the 120V Phase-to-Neutral Wye input wiring for the user wall plug. See Figure 2-8 for the correct receptacle wiring.

Figure 2-7 120V Nominal Phase-to-Neutral Wye Input Connections

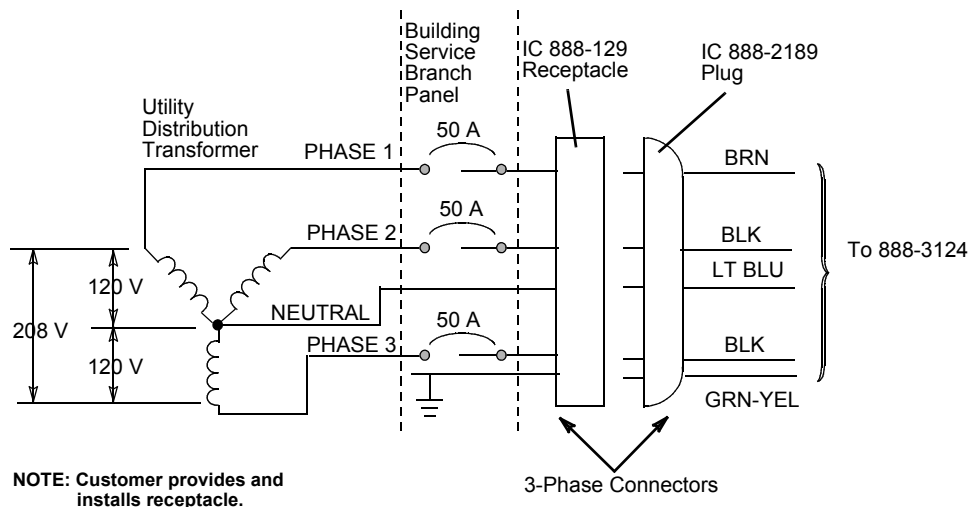

Figure 2-8 120V Nominal Phase-to-Neutral Wye Mating Receptacle Wiring

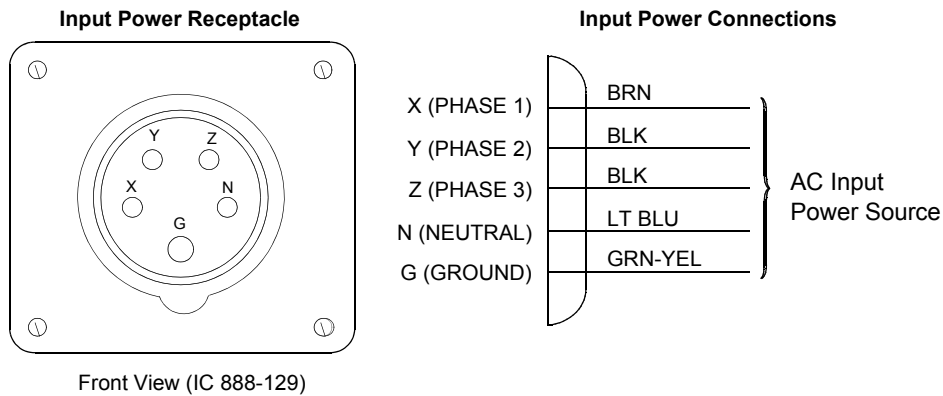
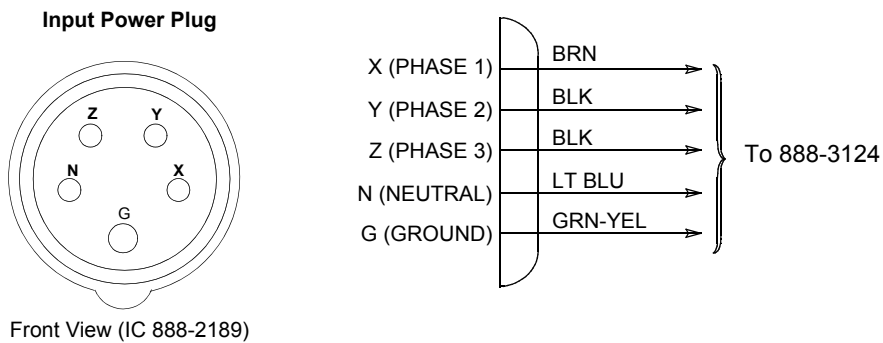

Figure 2-9 120V Nominal Phase-to-Neutral Wye Plug Wiring



220-240 VAC input Power Configuration Range

For this configuration, the system requires 3-phase input power service of 220-240 VAC wye connected, 4-wire plus safety ground, 50/60 Hz, 32 A per phase. The test system is supplied with a 12 ft (3.7 m) power cable terminated with an IC 888-204 or equivalent 4-pole, 5-wire grounding plug at the user's end and an IC connector 888-3124 or equivalent at the tester end. Figure 2-10 illustrates the 220/240V Phase-to-Neutral Wye input wiring for the user wall receptacle (IC 888-129 or equivalent). This receptacle is to be procured and installed by the customer prior to delivery of the system. Figure 2-12 illustrates the 220/240V Phase-to-Neutral Wye input wiring for the user wall plug. See Figure 2-11 for the correct receptacle wiring.

Figure 2-10 220 and 240 VAC Nominal Phase-to-Neutral Wye Input Connections

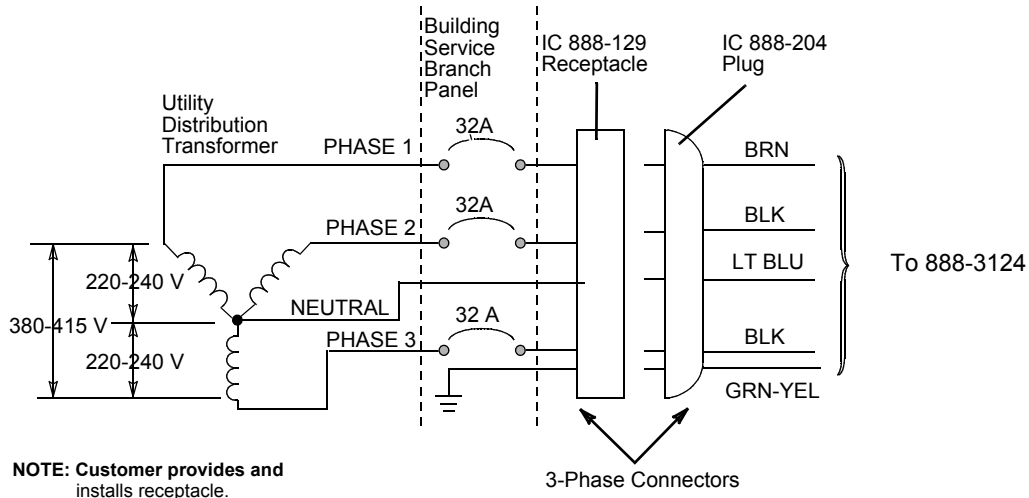

Figure 2-11 220, and 240 VAC Nominal Phase-to-Neutral Wye Mating Receptacle Wiring

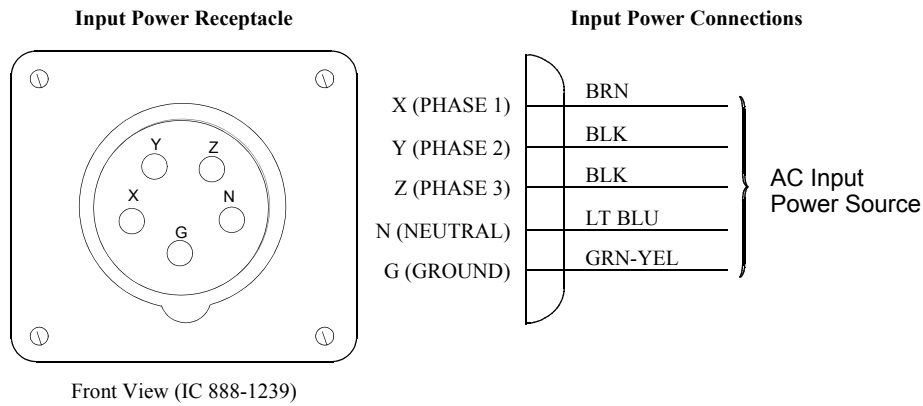

Figure 2-12 220, and 240 VAC Nominal Phase-to-Neutral Wye Plug Wiring

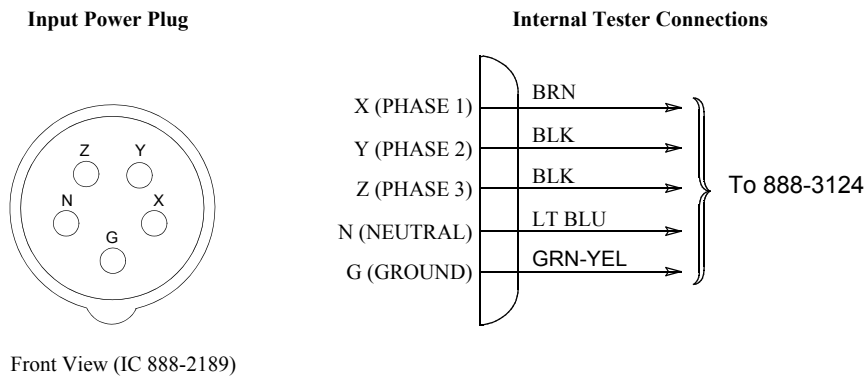
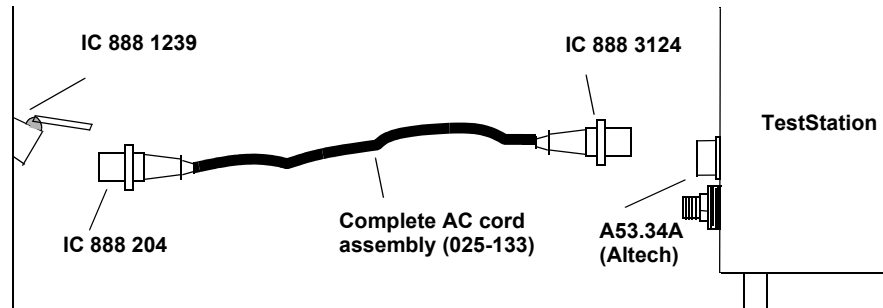

Figure 2-13 AC Connection Components



Vacuum Pump (Option) Input Power Requirements

The optional Busch vacuum pump is not connected to the system power. The customer is responsible for providing and connecting 3 phase AC input power to the vacuum pump motor. When the pump is located away from the system, some method of turning the pump on and off near the system is desirable.

The AC outlet for the pump should be wired by the customer before the system arrives. The pump must be connected according to the electrical codes through a fused switch to protect the motor against electrical or mechanical overloads. Pump AC wiring connection information is provided in the pump manufacturer's manual.

The Busch pump is rated at 3 horsepower. The pump is supplied with a 230/460 V, 3 phase, 60-Hz motor and also operates at the following voltages: 208 V, 3 phase, 60 Hz; 380 V, 3 phase, 50 Hz; and 190 V, 3 phase, 50 Hz.

For example, a typical Busch pump rated at 3 horsepower is rated at the following for these 3 phase AC 60Hz input power values:

208, 230/460 VAC phase-to-phase

9.1, 8.9/4.45 Amps AC

See the *Vacuum Requirement* for additional information describing the pump, hoses and couplings used between the pump and the system.

Vacuum Requirement

Vacuum is used to provide mechanical and electrical contact between the system receiver, test fixture, and unit-under-test (UUT). The vacuum required depends on the physical properties of the UUT you are testing (the number of holes in the board, the number of components on the board, the number of fixture vacuum ports, and the board surface area). The system's input vacuum requirement is 40 cfm (1.13 cubic meters/min) minimum vacuum flow; vacuum pressure is 23 inches Hg (77.97 kPa) minimum and 29.5 inches Hg (100 kPa) maximum.

The customer is responsible for providing and connecting AC input power to the vacuum pump motor and connecting the vacuum fittings to the system. See Chapter 4 for additional information on the vacuum pump.

Compressed Air Requirement

It is the customer's responsibility to supply filtered, compressed dry air to the system's air inlet connection. Compressed air is required to operate all system vacuum valves. The compressed air requirement at the air inlet connection fitting, located on the rear of the power bay, is 80 to 100 psi (5.6 to 7.0 kg/sq meter).

The air inlet connection on the pin bay is a female fitting. The male fitting plus a 92 in. (2.34 m) hose is included with the system in Compressed Air Hose Kit PN 9010-0188. See Chapter 4 for additional information on the compressed air hose kits.

Cooling Requirement

The site cooling plant must be able to compensate for the heat produced when the system is in operation. The heat produced by the system (and external peripherals) is computed based upon the system's rated electrical power. The rated electrical power is 15 kW for a system operating with 120 VAC input. The rated electrical power is 21 kW for a system operating with 240 VAC. Therefore, the installation site should be capable of removing 52.0 K BTU/h of heat generated by the dissipated power for a system operating with 120 VAC input power and 72.0 K BTU/h for a system operating with 240 VAC input power.

Test Fixture Procurement

CAUTION

To prevent equipment damage, the maximum weight of a test fixture, on a TestStation 12X must not exceed 140 pounds (63 kilograms), and on a TestStation LX must not exceed 300 pounds (136 kilograms).

The test fixture is the adaptor that holds the board to be tested and makes electrical contact with the circuit nodes on the board. Each different board type usually requires its own fixture. The user has the option of: (1) buying an assembled/wired test fixture from a fixture supplier (ready for system use), or (2) assembling/wiring a test fixture from a kit purchased from a fixture supplier. The *Fixture Information Manual* and *Test Fixture Manual for Standard Pin Count Test Systems* are included in the system's documentation set.

There are two connector pins on receiver position 3 that provide an electrostatic discharge (ESD) ground path from the fixture and its ESD points. See the position 3 description in Chapter 2 of the *Test Fixture Manual for Standard Pin Count Test Systems* or the *Test Fixture Manual for Large Pin Count Test Systems* for wiring information.

Receiver Sizes

The receiver size determines what adapters and fixtures you can use on the test system. The TestStation 12X uses a Standard receiver and the TestStation LX uses a Large receiver.

Adapter Types

There are adapters that you can mount on the TestStation 12X and TestStation LX to accommodate different fixture sizes. They are:

- L Adapter
- 18-Slot Adapter
- 15-Slot Adapter
- 19-Slot Large-Half Adapter

Ethernet Requirement

If you plan to use Ethernet with the test system, it is your responsibility to purchase and install the cables for an Ethernet installation.

Chapter 3

Safety Considerations in Site Planning

Introduction

This chapter contains considerations in site planning relating to the safety of both personnel and the equipment.

System Grounding

A separate (10 ft [3 m]) safety-ground wire is supplied with the system and must be connected from the system's ground lug to a known earth ground.

Methods of grounding the system are:

- Connection to a water pipe or known earth ground
- Connection to a ground stake

A long steel rod is placed in a hole drilled through the floor into the ground below. Install according to country and local electrical codes.

Fire Precautions

Take all necessary precautions against fire. Store permanent documents, tape cartridges, and spare parts, etc in a fire-proof area. Overhead sprinklers can be used if the water heads are not directed at the equipment. Additionally, sprinkler heads should not be located directly over the system or its fan intake/exhaust path. Locate wall-mounted CO₂ (carbon dioxide) fire extinguishers within easy reach of the system.

Personnel Safety Considerations

Facility personnel (especially operators) should be familiar with the emergency power shut-down procedure and with how to notify the fire department. Preparedness might well result in saving expensive equipment.

An operator is adequately protected from electrical shock. Nevertheless, personnel trained in first aid for electrical shock and burns should be always available.

Unauthorized personnel should not remove any of the system's panels, which are provided for system cooling and protection of the electronics. Review the instruction manuals for precautions needed to assure safe operation.

Chapter 4

Additional Site Requirements

Vacuum Pump

Two basic types of pumps are used to supply vacuum to a system; each is dependent on its application. Generally, sites with one system use a mechanical vane-type pump. This is the type of pump available from Teradyne. Sites operating a system that has solder suckers connected to the same vacuum system should employ a water ring-seal type pump. The water-seal type pump is recommended because it is not susceptible to contaminants in the vacuum line. When multiple systems and/or additional production applications use the same vacuum pump, an air reservoir with a metered valve is suggested to provide a constant level of pressure on the vacuum lines.

Teradyne recommends the Busch R5-series pump, model 063-138 (40 cfm [1.13 cmm] at 60 Hz; 31 cfm [0.88 cmm] at 50 Hz). Teradyne stocks this pump as PN 1765955300. A vacuum pump filter kit for this pump is available from Teradyne as PN 1765958000.

Vacuum Pump Hookup Kit

The vacuum pump hookup kit (PN 2272158000) connects the system to the vacuum pump.

This kit contains the following items:

- Two vacuum hose assemblies (PN 2270040100)

The length of each vacuum hose assembly is 46 ± 1 in. (116.84 ± 2.54 cm). This assembly consists of the hose with end-fitting cuffs already cemented to it.

- One nipple (PN 2267702000)
- One adapter coupling (PN 5270488200)

Obtaining Longer Vacuum Hose Assemblies

The maximum length of the vacuum hose assembly can be up to 100 feet (30.48 m). A longer hose assembly can be obtained from:

Greene Rubber Company
20 Cross Street
Woburn, MA 01801
Telephone (781) 937-9909
FAX 781 937 9739

The Green Rubber Company supplies the complete hose assembly (with the cuffs cemented to the hose) to your specified length.

For an additional vacuum hose assembly, order the following:

Hose	Flexaust 1.125 inch ID type CWC with two extra Neoprene coatings.
End Fittings	Flexaust 1.125 inch ID molded screw cuffs cemented to the hose.
Color	Black
Application	For use at negative pressure to 29 inches Hg (approx 20 torr)

Oil

The pump is shipped without oil. It is your responsibility to provide oil. The type used should always be non-detergent SAE (Society of Automotive Engineers) 30-weight, automotive type motor oil. The Busch pump requires approximately two quarts (1.89 liters).

Compressed Air Hose Kits

The following sections describe two different air hose kits.

Compressed Air Hose Kit

This kit (PN 9010018800) connects from your site's compressed air source to the system. Every system is shipped with this compressed air hose kit. See Figure 4-1.

This kit includes one each:

- Compressed air hose (92 in., 2.3 m), PN 5270004400
- Double-end quick-connect stem, PN 5270004200

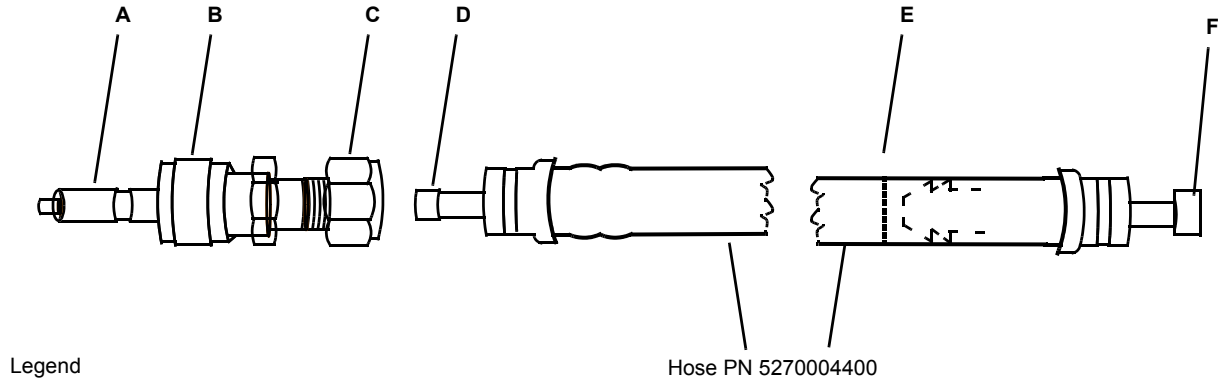
Figure 4-1 Compressed Air Hose Kit, PN 9010018800 (Stem and Hose)**Legend**

- | | |
|---|--|
| <p>A. Stem end fitting to system compressed air port.</p> <p>B. Double-end, quick-connect stem, PN 5270004200.
This fitting, combined with the mating half on system, traps air in the system if disconnected. This prevents the fixture from rapidly descending onto the receiver if the hose is disconnected while lift rods are in the raised position.</p> <p>C. Compression fitting end.
To install: Loosen nut. Do not lose ferrules inside. Insert tube adapter on hose. Hand tighten 1-1/4 turns with a wrench After installation, do not disconnect this fitting connection.</p> | <p>D. Both tube adapter ends of hose accept 1/4 in. compression fitting.</p> <p>E. If necessary, cut here to attach barb fitting.</p> <p>F. The customer must supply a fitting that attaches this hose to the factory compressed air source. The end of the hose accepts a 1/4 in. compression fitting or, the customer can cut the hose beyond the tube adapter and attach a barb fitting that attaches this hose to the factory compressed air source.</p> |
|---|--|

If the customer is to use the compressed air hose (PN 5270004400), the customer must supply and install a $\frac{1}{4}$ -in. compression fitting/adapter that attaches this hose to its factory compressed air source. See item F in Figure 4-1.

When the customer's compressed air hose, which must accept a $\frac{1}{4}$ -in. compression fitting, is to be connected to the system, the double-end quick-connect stem (PN 5270004200, part of Compressed Air Hose Kit PN 9010018800) is inserted in the customer's hose, and then the stem is connected to the system's compressed air port on the rear of the pin bay. The compressed air hose (PN 5270004400), which is part of Compressed Air Hose Kit PN 9010018800, is not used in this application.

Compressed Air Hose Extension Kit

You can purchase the hose extension kit (PN 9010018900) when you need a longer hose.

This optional kit includes one:

- Compressed air hose (92 in., 2.3 m), PN 5270004400
- Union compression fitting (0.25 in., 6.35 mm) PN 5270004300

This fitting is the union that connects two hoses together, increasing their length. This fitting will be installed in the end of each of the two hoses being connected together.

Modem Requirements

A telephone line must be available if you purchased a modem. Teradyne recommends a standard direct line in and out of the building. If a direct line is not available, certain conditions must be considered. If a PBX system is used, the PBX must be programmed for both data and voice if a phone is to be used with both.

A telephone jack needs to be installed on the phone line. A standard RJ11C modular telephone jack (normally used for office and residential phones) is recommended. Teradyne recommends that you have one phone line for each system. Cable routing must take into consideration an environment that provides the best possible clean and noise-free atmosphere; for example, do not route a cable near a 3-phase, 400-V power cable.

Fixture Storage

CAUTION

Store test fixtures carefully to prevent possible damage or corrosion to their electrical contacts.

Place a fixture storage rack (on wheels) near the system for fast and easy access to system test fixtures.

Circuit-Board Storage Racks

Circuit-board storage racks (on wheels) facilitate test system throughput. Placing a rack of untested boards on one side of the operator and a rack of tested boards on the other side of the operator provides an efficient manner of handling circuit boards. An additional rack for defective boards can also be useful. In addition, the racks permit easy movement of circuit boards to and from the system within the production area.

CAUTION

Never place circuit boards on the surface of the test system. If you desire, place an ESD mat on the surface.

Telephone Installation

It is suggested that a telephone for in-plant use be available on or near the system. This enables the operator to contact supervisory personnel in production, test engineering, and application engineering when necessary.

Recommended Supplies

Teradyne recommends that you have the following supplies on-site.

Printer Paper

Seiko model DPU-5347 thermal printer paper is 3.15 in. (80 mm) wide on a 3.5 in. (90 mm) diameter roll. Paper thickness is 2.6"0.2 μ m. (66"5 μ m). One case (20 rolls) can be purchased from Teradyne as PN 9021024900, or from a computer-related printer paper supplier. Seiko's part number for this paper is #TP5300-100C.

PC Floppy Drive Diskette

The high-density, preformatted 3¹/₂-inch diskette for the PC's floppy drive is available as Teradyne PN 9021002500 (one diskette). Diskettes can also be ordered from most computer accessory suppliers.

CD ROM Drive CDs

CDs for the PC's CD Rom drive are available as Teradyne PN 091-607 (one CD). CDs can also be ordered from most computer accessory suppliers.

System Air Filter Kit

A system air filter kit (P/N 09306800) contains replacement air filters for the test system. The complete list of filters is found in the *TestStation Theory and Maintenance Manual*.

Additional Suggested Site Considerations

You may want to implement some of these suggestions at your site.

- Install a bulletin board near the system for posting messages.
- Obtain static-avoidance equipment.
- Keep spare nails available for test fixtures.
- Provide space in your facility for storing printer-paper.
- Provide a portable vacuum cleaner (with non-metallic bristle-brush fitting on end of hose) for cleaning the top of the fixture before the start of board testing.
- Keep a maintenance log, particularly for preventive maintenance. Secure all maintenance documentation, including the documentation for peripheral items, so that certain supply items and options can be obtained and preventive maintenance schedules are available when needed. Appendix B in the *TestStation Theory and Maintenance Manual* (part of the Teradyne manual set) contains a series of blank site-status logging forms.
- Consult Teradyne about a maintenance contract and other services.

Appendix A

Site Preparation Checklist

Introduction

The following activities should be part of site preparation planning and initiated after they have been resolved. If you require site planning assistance, contact the Teradyne Technical Support Center. See *Using This Manual* for more information about contacting the Teradyne Technical Support Center.

► To confirm the site preparation activities:

1 *Identify the desired location for installation of the

- System _____
- Vacuum pump (if applicable) _____

2 *Verify that all environmental requirements are met

- Temperature _____
- Humidity _____
- Cleanliness _____
- Free of airborne contaminants _____

3 Plan the delivery route to the installation site _____

4 *Obtain required, stable input power for the site

- System power available at system location _____



Note:

System installation requires a power receptacle compatible with the National Electrical Manufacturer's Association (NEMA) standards as well as local electrical codes. Make certain, when ordering the power receptacle from your vendor, that the lead time for the receptacle's delivery allows for its installation prior to the planned system delivery date.

- Date that power receptacle was ordered _____
- Power receptacle part number _____
- Vacuum pump power (if applicable) _____

5 *Install a safety earth ground according to specifications _____

* Denotes a critical item. The system cannot be installed without these requirements being met.

- 6 Determine/install the type of flooring (unless cabling is to be installed under a raised floor) _____
- 7 Design the equipment, furniture, and storage layout for the site
 - *Leave a minimum of 40 in. (101.6 cm) from any side of the system and the nearest wall, or any other obstacle that could restrict system access or air flow _____
 - *Leave a minimum of 12 in. (30.5 cm) between the sides of the system and the nearest peripheral. _____
 - Consider future expansion _____
 - Consider safety and comfort of personnel _____
 - Consider any required cabling to local and remote peripherals _____
- 8 Allow for the following items in the site preparation plan:
 - *Length of the vacuum line to the system _____
 - *Length of the compressed air line and connection to the system _____
 - *Obtain a compressed air fitting to attach supplied hose to air source _____
 - Telephone and modem lines (analog line is required) _____
 - Fire extinguisher _____
 - Sufficient space for other equipment, such as board carts or racks, to be moved around the system _____
 - Storage equipment for fixtures _____
 - Storage for additional supplies such as printer paper and ribbons, tape cartridges, PC diskettes, system air filter kit, and the filter kit for the Busch vacuum pump _____
- 9 Provide for air conditioning (if applicable) _____
- 10 Static avoidance equipment _____
- 11 Determine if the following items will be present or incorporated at the site
 - If any layered software is to be purchased, identify the loading, testing, and acceptance criteria _____
 - Teradyne's Access (remote support) requirements _____
 - Determine Ethernet or other networking requirements for the site. Ensure that the system's configuration matches the site requirements. _____
 - Verify the network host system protocol _____
 - Confirm that the Ethernet node is functional prior to the system's delivery _____

* Denotes a critical item. The system cannot be installed without these requirements being met.

Index

A

Air Filter
kit 4 - 5

C

Compressed Air
filter 4 - 5
hose kits 4 - 2-4 - 3
requirement 1 - 3, 2 - 13
Cooling Requirements 1 - 3, 2 - 13

D

Diskettes
floppy drive 4 - 5

E

Environmental Requirements 1 - 2
operating, system 2 - 7
PC 2 - 7
storage, system 2 - 7
Ethernet
requirements 2 - 14

F

Filter
air 4 - 5
compressed air 4 - 5
Fire Protection 3 - 1
Fixture
procurement 2 - 13
storage 4 - 4

G

Grounding
system 3 - 1

H

Hookup Kit
compressed air 4 - 2-4 - 3
vacuum pump 4 - 1

O

Oil
vacuum pump 4 - 2
Operating Environment
system 2 - 7

P

Power Requirements 1 - 2
system 2 - 8
vacuum pump 2 - 12
Printer
paper 4 - 5

R

Requirements
compressed air 1 - 3, 2 - 13
cooling 1 - 3, 2 - 13
environmental 1 - 2, 2 - 7
Ethernet 2 - 14
power 1 - 2
space 1 - 2, 2 - 1
system grounding 3 - 1
system input power 2 - 8
vacuum 1 - 2, 2 - 12
vacuum pump input power 2 - 12
vacuum pump location 2 - 6

S

Safety
fire 3 - 1
personal 3 - 1
Space Requirements 1 - 2, 2 - 1
Storage
environment, system 2 - 7
fixture 4 - 4
Storage Racks
circuit boards 4 - 4
Supplies
floppy diskettes 4 - 5
printer paper 4 - 5
System Input Power Requirements 2 - 8

T

Telephone 4 - 4
Test Fixture
procurement 2 - 13

V

Vacuum Pump
description 4 - 1
filter kit 4 - 1
hookup kit 4 - 1
hose 4 - 1-4 - 2
location 2 - 6
oil 4 - 2
power requirements 2 - 12
Vacuum Requirements 1 - 2, 2 - 12

W

Weight

- plant floor loading capacity 1 - 2
- system and peripherals 2 - 1