

# The GENERAL RADIO EXPERIMENTER

VOL. VII. Nos. 11 and 12

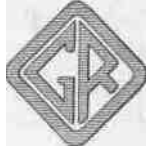

APRIL-MAY, 1933

## ELECTRICAL COMMUNICATIONS TECHNIQUE AND ITS APPLICATIONS IN ALLIED FIELDS

### THE CONVENIENT MEASUREMENT OF C, R, AND L

**T H E** important considerations in the large majority of bridge measurements made in the average experimental laboratory are the ease and speed of making the readings, and the ability to measure any values of resistance, inductance, or capacitance, as they may exist in any piece of equipment. A completely satisfactory bridge should immediately indicate the answer to such questions as the following:

Is the maximum inductance of this variable inductor at least 5 mh, its minimum inductance 130 uh, and its direct-current resistance less than 4  $\Omega$ ?<sup>1</sup>

Has this choke coil at least 20 h inductance and an energy factor  $Q$  of at least 20?

Has this tuning condenser a maximum capacitance of 250 uuf and a 20 to 1 range?

Has this filter condenser at least 4  $\mu f$  capacitance and a power factor of only 0.5%?

Is the resistance of this rheostat 200 k  $\Omega$ ?

<sup>1</sup> These are the standard abbreviations of the Institute of Radio Engineers. Note that 1 m $\Omega$  is 0.001 ohm and that 1 M $\Omega$  is 1,000,000 ohms.

Is the zero resistance of this decade-resistance box only 5 m $\Omega$ ?

The TYPE 650-A Impedance Bridge will furnish the answers to all these questions and many others. It will measure direct-current resistance over 9 decades from 1 m $\Omega$  to 1 M $\Omega$ , inductance over 8 decades from 1  $\mu h$  to 100h, with an energy factor ( $Q = \omega L/R$ )

up to 1000, capacitance over 8 decades from 1 uuf to 100  $\mu f$ , with a dissipation factor ( $D = R\omega C$ ) up to unity.<sup>2</sup>

These results are read directly from dials having approximately logarithmic scales similar to those used on slide rules. The position of the decimal point and the proper electrical unit are indicated by the positions of two selector switches. Thus the CRL multiplier switch in Figure 1 points to a combined multiplying factor and electrical unit of 1  $\mu f$  so that the indicated ca-

<sup>2</sup> The fact that this bridge is capable of measuring a condenser with large energy losses makes it necessary to distinguish between its dissipation factor  $R/X$  and power factor  $R/Z$ . The two are equivalent when the losses are low.

Since the bridge measures  $R\omega C$  directly, the term dissipation factor has been used, even though the two terms are, for most condensers, synonymous.

capacitance as shown on the CRL dial is 2.67  $\mu f$ , because the D-Q multiplier switch has been set on C for the measurement of capacitance. It also shows that the DQ dial is to be read for dissipation factor D with a multiplying factor of 0.1 yielding 0.26.

If the condenser had a smaller dissipation factor, this D-Q multiplier switch would have been set for the D dial with a multiplying factor of 0.01. Thus the D dial, as shown in Figure 1, indicates a dissipation factor of 0.0196 or a power factor of 1.96%.

For the measurement of pure resistance the D-Q multiplier switch would be set at R so that the CRL dial indicates a resistance of 2.67  $\Omega$ .

For the measurement of inductance the D-Q multiplier switch would be set at L and the CRL dial indicates 2.67 mh. Using the DQ dial the multiplier is 1 and the energy factor  $Q$  as shown in Figure 1 is 2.6. Had the coil under measurement been a large iron-core choke coil, the CRL multiplier switch might have been set at the 10 h point, thus indicating 26.7 h. Then the D-Q multiplier switch would have been set to indicate the Q dial with a multiplier of 100 and an energy factor  $Q$  of 41 as read on the Q dial.

The ease of balancing the bridge depends on the use of the logarithmically tapered rheostats and the two multiplier switches. To illustrate this, take first the measurement of direct-current resistance.

With the unknown resistor connected to the R terminals, the D-Q multiplier switch is set at R, the GENERATOR switch at DC, and the DETECTOR switch at SHUNTED GALV. The galvanometer immediately deflects, indicating by the direction of its deflection which way

the CRL multiplier switch should be turned to obtain approximate balance. The CRL dial is then turned for exact balance, having thrown the DETECTOR switch to the GALV. position.

Because the calibration of the CRL dial extends to 0, the bridge can be balanced for a number of different settings of the CRL multiplier switch. This is very helpful in ascertaining the approximate value of a resistor. Obviously greatest accuracy of reading is obtained when the balance point on the CRL dial is within the main decade which occupies three-quarters of its scale length.

An inductor or condenser is measured by connecting it to the CL terminals. The GENERATOR switch is set at 1 KC. and the DETECTOR switch at EXT, head telephones being connected to the EXTERNAL DETECTOR terminals. The D-Q multiplier switch is set on L or C as the case demands, pointing to the DQ dial. The CRL dial is swept rapidly over its range to indicate the direction of balance. The CRL multiplier switch is then moved in the direction indicated and balance obtained on the CRL dial. The DQ dial is then turned for balance. From its setting the desirability of using the D dial or the necessity of using the Q dial will be indicated.

The reactance standards are *mica* condensers having all the excellent characteristics of the TYPE 503 Condensers described in the *Experimenter* for January.

The bridge circuit used for measuring condensers is the regular capacitance bridge having pure resistances for its ratio arms. Maxwell's bridge is used for inductors, whose energy factors  $Q$  are less than 10. Above this value Hay's bridge is used. The interdependence of the two balances of these last two

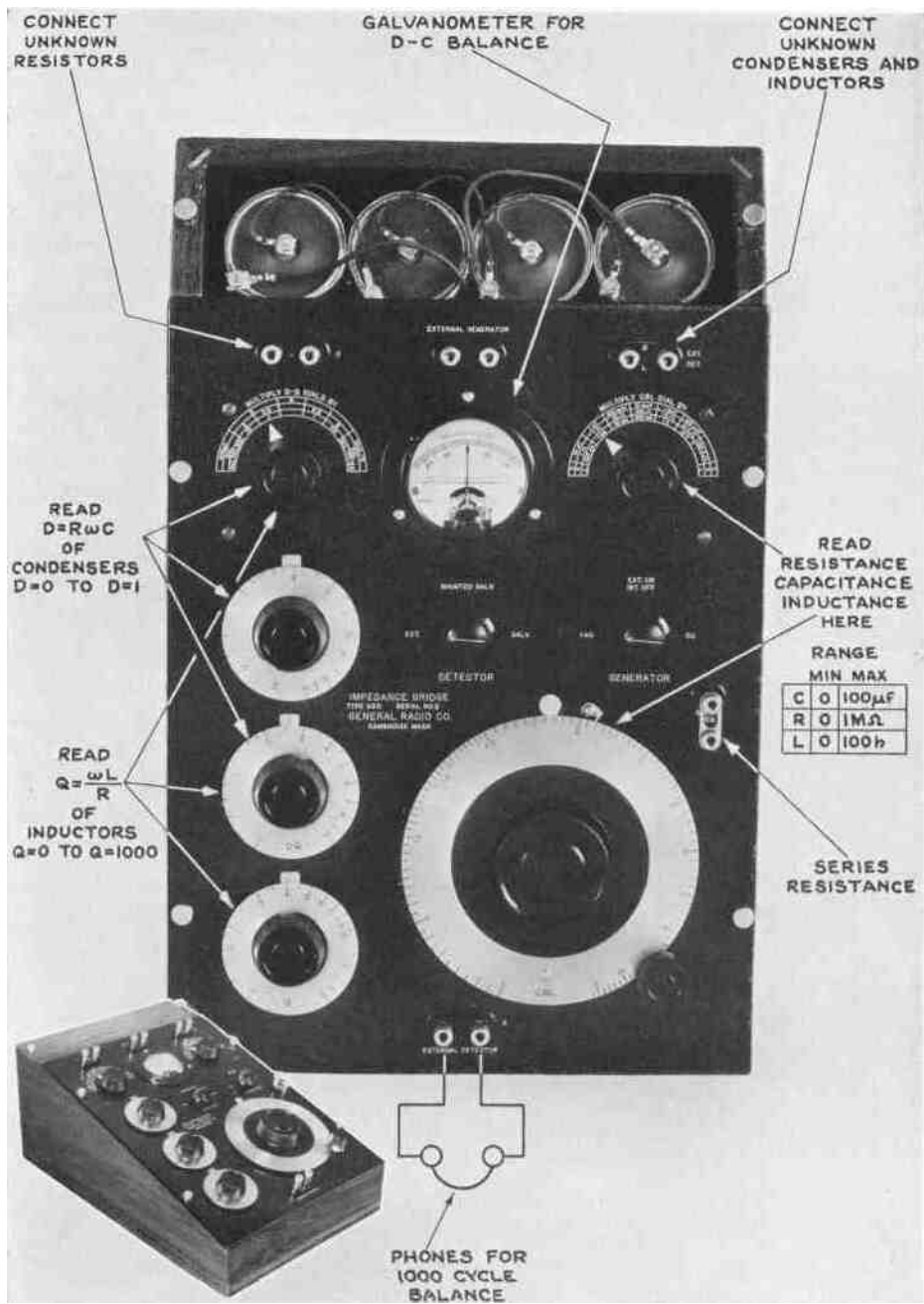

FIGURE 1. This photograph of the panel emphasizes the simplicity and wide range of the impedance bridge. In the corner at the left is a side view of the instrument

bridge circuits cannot, of course, be prevented, but the use of the logarithmic rheostats for balancing makes it very easy to follow the drift of the balance points.

The accuracy of calibration of the CRL dial is 1% over its main decade. It may be set to 0.2% or a single wire for most settings of the CRL switch. The accuracy of readings for resistance and capacitance is 1%, for inductances 2%, for the middle decades. The accuracy falls off at small values because the smallest measurable quantities are 1 *mo*, 1 *uuf*, and 1 *uh*, respectively. Zero readings are approximately 10 *mO*, 4 *uuf*, and 0.1 *uh*, respectively. The accuracy falls off at the large values, becoming 5% for resistance and capacitance and 10% for inductance. The accuracy of calibration of the DQ dials is 10%. The accuracy of readings for dissipation factor and energy factor is either 20% or 0.005, whichever is the larger.

The power for the bridge is drawn from four No. 6 dry cells mounted at the back of the cabinet. The liberal size of these batteries assures a very long life. External batteries of higher voltage

may be used to increase the sensitivity of the bridge for the measurement of the highest resistances. The internal batteries operate a microphone hummer for the production of the 1-kc current. The capacitance of this hummer to ground is small and has been allowed for in the bridge calibration.

An external generator may be used, though its capacitance to ground may introduce considerable error. Subject to this limitation, the frequency may be varied over a wide range from a few cycles to 10 kc. The reading of the CRL dial is independent of frequency. The readings of the D and DQ dials must be multiplied by the ratio of the frequency used to 1 kc to give the correct values of dissipation and energy factors, while the reading of the Q dial must be divided by this ratio. For frequencies other than 1 kc the ranges of the DQ dials are altered so that they will no longer overlap. Additional resistance may be inserted by opening the SERIES RES. terminals. The TYPE 526 Rheostats, described on page 7, are quite satisfactory for this use.

—ROBERT F. FIELD

#### SPECIFICATIONS

Dimensions: Panel, (width) 12 x (depth) 16 inches. Entire instrument, (width) 12 x (depth) 23 x 9 inches, over-all.

Net Weight: 22 pounds. Batteries, 8 1/4 pounds additional.

Code Word: BEAST.

Price: \$175.00, without batteries.

### THE SKELETON-TYPE IMPEDANCE BRIDGE

THERE are many individual bridge measurements for which the wide range of the TYPE 650-A Impedance Bridge is unnecessary, while its ease and speed of making readings are essen-

tial. Examples of these uses are the following:

Limit bridges for resistance, inductance, and capacitance, whose ranges may be changed easily, though not in-

stantaneously. Bridges for the individual experimenter who is willing to forego the convenience of multiple switching and to manually interconnect the various arms of the bridge for the sake of a considerable reduction in price.

Bridges for schools and colleges with which the student may make up the various bridge circuits.

The TYPE 625-A Bridge is eminently adapted to this type of measurement. It consists of a skeleton bridge circuit, in which one arm contains a direct-reading logarithmic rheostat and the other three arms are brought out to pairs of terminals. A 1-kc microphone hummer, batteries, and their associated switches are also connected in circuit. TYPE 500 Resistors may be used as ratio arms, TYPE 505 Condensers as reactance standards, and TYPE 526 Rheostats as added resistors to indicate energy factor  $Q$  and dissipation factor  $D$ . These resistors and condensers are plugged directly into the bridge terminals. The rheostats can be connected through TYPE 274 Plugs and cables.

The panel arrangement is shown in Figure 1. The wiring diagram is engraved in the lower left corner. The slide on which the ratio arms and standards may be stored is opened for inspection. Appropriate values of these units are 10,000  $O$ , 1000  $O$ , 100  $O$ , 1  $uf$ , and 0.01  $uf$ . With these units resistance may be measured over 6 decades from 1  $O$  to 1  $MO$ , inductance over 6 decades from 100  $uh$  to 100 h, capacitance over 6 decades from 100  $uuf$  to 100  $uf$ . By the addition of a few other units these ranges may be extended to the same values as are covered

by the TYPE 650-A Impedance Bridge. (See page 3.)

Table I shows the proper combinations of these plug-in units for the entire range of values mentioned. This table is for all settings of the logarithmic rheostat between 10  $O$  and 10,000  $O$ .

Another table giving the values of the added resistance to be obtained from the TYPE 526 Rheostats, for values of dissipation factor  $D$  up to 1

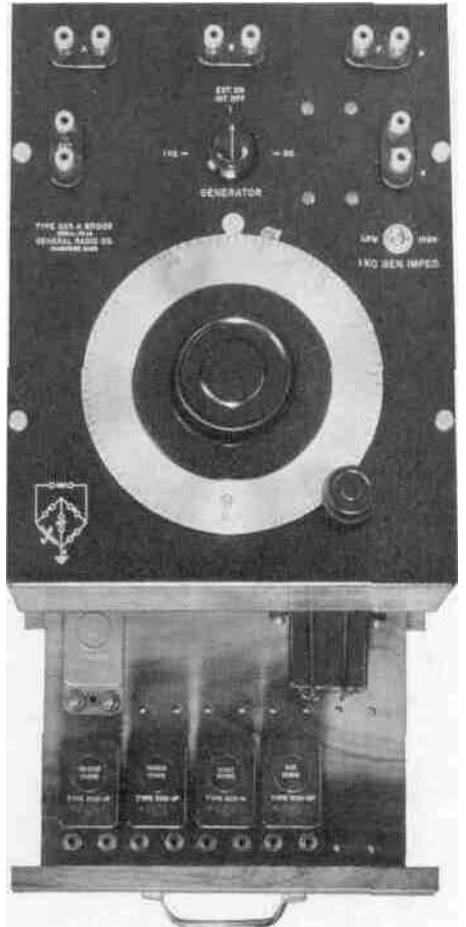

FIGURE 1. The skeleton-type bridge with the drawer pulled out to show the method of storing standard resistors and condensers when not in use



FIGURE 2. TYPE 625.A Bridge

and values of energy factor  $Q$  up to 1000, is shown in the instruction book accompanying the bridge.

The wiring diagrams of the various

bridges which should be used are shown in Figure 3. Capacitance is measured on a simple bridge having two resistance arms and two capacitance arms. Inductance is measured in terms of a standard condenser. The resistor added for making the resistance balance is placed either in parallel or in series with the standard condenser. The parallel connection is Maxwell's bridge and may be used for all values of energy factor  $Q$ , except that for large values the added resistance is too large to be obtainable on a variable resistor. The series connection is Hay's bridge and while it may also be used for all values of energy factor  $Q$ , the complicated correction term containing frequency becomes negligible only when  $Q$  is greater than 10. — ROBERT F. FIELD

TABLE I

Values of C, R, and L that can be measured with recommended standards. Unknown quantities in bold face type.

A ARM	B ARM	PARM	N DIAL
100 $\Omega$	10,000 $\Omega$	1000 $\Omega$ -1,000,000 $\Omega$	Unknown quantities (printed in bold face type) correspond to the complete range of 10 $\Omega$ -10,000 $\Omega$ , covered by the Logarithmic Rheostat N. Greatest accuracy is obtained by using the main decade on N ( $N = 1000 \Omega$ to $N = 10,000 \Omega$ ).
1000 $\Omega$	10,000 $\Omega$	100 $\Omega$ - 100,000 $\Omega$	
10,000 $\Omega$	10,000 $\Omega$	10 $\Omega$ - 10,000 $\Omega$	
10,000 $\Omega$	1000 $\Omega$	1 $\Omega$ - 1000 $\Omega$	
10,000 $\Omega$	100 $\Omega$	0.1 $\Omega$ - 100 $\Omega$	
10,000 $\Omega$	10 $\Omega$	0.01 $\Omega$ - 10 $\Omega$	
10,000 $\Omega$	1 $\Omega$	0.001 $\Omega$ - 1 $\Omega$	
100 $\Omega$	0.1 $\mu f$ - 100 $\mu f$	1 $\mu f$	
1000 $\Omega$	0.01 $\mu f$ - 10 $\mu f$	1 $\mu f$	
10,000 $\Omega$	1000 $\mu f$ - 1 $\mu f$	1 $\mu f$	
1000 $\Omega$	100 $\mu f$ - 0.1 $\mu f$	0.01 $\mu f$	
10,000 $\Omega$	10 $\mu f$ - 0.01 $\mu f$	0.01 $\mu f$	
10,000 $\Omega$	1 $\mu f$ - 1000 $\mu f$	1000 $\mu$	
100mh-100h	10,000 $\Omega$	1 $\mu f$	
10 mh- 10 h	1000 $\Omega$	1 $\mu f$	
1mh- 1h	10,000 $\Omega$	0.01 $\mu f$	
100uh-100mh	1000 $\Omega$	0.01 $\mu f$	
10 uh- 10 mh	100 $\Omega$	0.01 $\mu f$	
1 uh- 1 mh	10 $\Omega$	0.01 $\mu f$	

**SPECIFICATIONS**

**Accuracy:** The scale of the logarithmic rheostat is correct to 1%. The frequency of the internal microphone hummer is 1000 cycles to within 5%.

**Power Supply:** Power for driving the hummer and for d-c measurements is derived from two 4.5-volt batteries (Burgess No. 2370 or Eveready No. 771).

**Accessories:** Balance detectors suggested: head telephones for a-c measurements; zero-center, 200-ua full scale galvanometer for d-c measurements.

**Standards:** The following units make suitable standards and they can, for convenience, be ordered at the same time as the bridge if desired.

**TYPE 500 RESISTORS**

(See page 12, Catalog G)

500-AP	1 <i>O</i>	\$2.00
500-BP	10 <i>O</i>	2.00
500-DP	100 <i>O</i>	2.00
500-HP	1000 <i>O</i>	2.00
500-JP	10,000 <i>O</i>	2.00

**TYPE 505 CONDENSERS**

(See January, 1933, *Experimenter*)

505-FP	0.001 uf	\$3.50
505-LP	0.01 uf	4.00
505-QP	0.05 uf	4.50

A 1-uf condenser is also available: TYPE 625-P1, Code Word BAIZE, Price \$2.00.

**Dimensions:** Panel, (width) 9x (depth) 12 inches. Cabinet, (height) 7 inches, over-all.

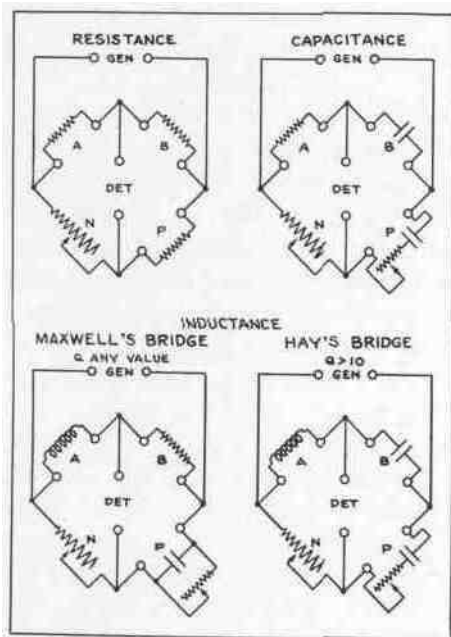

FIGURE 3. These are the basic circuits used in the TYPE 650-A Impedance Bridge and the ones recommended for use with the TYPE 625-A Bridge

Net Weight: 9 pounds. Batteries, 2 pounds additional.

Code Word: BEACH.

Price: \$.65.00 without batteries or the standards suggested in the *Accessories* paragraph above.

**MOUNTED RHEOSTAT-POTENTIOMETERS**



**TYPE 471 Rheostat-Potentiometers** are available mounted in drawn steel cases, the same size as used for the TYPE 247-G Variable Air Condenser. Each has an etched dial graduated in 50 divisions. The total resistance has been adjusted to within 2 1/2% of the rated value.

Type	resistance	Price
526-D	0-100 <i>O</i>	\$8.50
526-A	0-10000 <i>O</i>	8.50
526-B	0-10,000 <i>O</i>	8.50
526-C	0-100,000 <i>O</i>	8.50

## PITCH AND INTENSITY MEASUREMENTS WITH A VACUUM-TUBE OSCILLATOR

**T**HE psychological and physiological departments of many universities, including Brown, Oregon, Princeton, and Yale, are making use of modern electrical vacuum-tube oscillators and associated measuring equipment to increase the speed and precision of audio-sound demonstrations and researches.

Dr. Robert H. Seashore of the University of Oregon, who has used this equipment for some time, writes, "We find the oscillator most useful for a number of demonstrations and experiments in the psychological and musical courses and special research projects. So far, we have used it as follows:

"(1) To demonstrate the range of the most useful portion of the audible sound stimuli

"(2) To show the independent variation of intensity at any pitch

"(3) To show the lowest audible tones (in a telephone receiver)

"(4) To demonstrate beats and difference tones when sounded with a tuning fork or other instrument

"(5) To demonstrate the small variations in pitch which lead to 'consonant' or 'dissonant' sound combinations (with a tuning fork)

"(6) The most important function for our purposes, to be able to measure pitch discrimination by the method of paired comparisons at any place in the musical scale."

The central instrument for this work is a vacuum-tube oscillator which, when used to operate ordinary telephone receivers or radio loudspeakers, produces sound vibrations of the sort obtained from tuning forks and other mechanical vibrators. The electrical oscillator has the great advantage over such mechanical oscillators that the vibration frequency can be adjusted rapidly and accurately over a wide range and that the amplitude can be



Any pitch between 5 and 10,000 vibrations per second is obtainable from the TYPE 613-B Beat-Frequency Oscillator. Incremental variations on either side of a given frequency are obtained by means of the condenser at the left

adjusted from zero to maximum by one turn of a switch.

Any tone in the range from 5 to 10,000 cycles per second can be selected instantly by setting the large central dial on which the frequency is engraved. The overtone or harmonic content of these well-designed electrical oscillators is negligible.

Experimenters have found that it is desirable to be able to vary the pitch over a small range from some base frequency. For this the TYPE 539-P Incremental-Pitch Condenser is provided. It is a direct-reading vernier adjustment for the electrical oscillator for changing its pitch by a total of 100 vibrations per second for a rotation of a full half turn of a large dial. This dial is calibrated for 100 divisions, each one effecting a change in pitch of *exactly* one vibration per second.

The base frequency of the oscillator can be anything from 100 cycles per second (about an octave below middle C) to 10,000 cycles (over five octaves above). The incremental pitch will read correctly for any setting in this range. Sufficient power output (about 10 milliwatts) is available to cause a strong tone in head telephones. For classroom

demonstrations this sound volume can be enormously increased by the use of a vacuum-tube amplifier.

A third most useful auxiliary unit is a calibrated control of the volume of sound. The TYPE 529-B Attenuation Box is calibrated in steps of 2 decibels, the standard unit of relative sound volume, to cover a range from 0 to 60 decibels. This represents an attenuation control range from 0 to 1,000,000 in sound volume.

An interesting class demonstration is conducted by Dr. Harold Schlosberg of Brown University to determine, using the whole class and voting by a display of hands, the just noticeable difference of pitch at several frequencies. Then, with individuals selected from the class, using a headphone, the lower threshold of hearing at various frequencies is determined.

—ARTHUR E. THIESSEN

PRICES

*TYPE 613-B Beat-Frequency Oscillator.....	\$210.00
TYPE 539-P Incremental Pitch Condenser.....	50.00
TYPE 529-B Attenuation Box.....	34.00

\*This instrument must be modified slightly so that the incremental-pitch condenser can be used with it. The extra charge for this work and for the shielded connector is included in the price of the condenser.

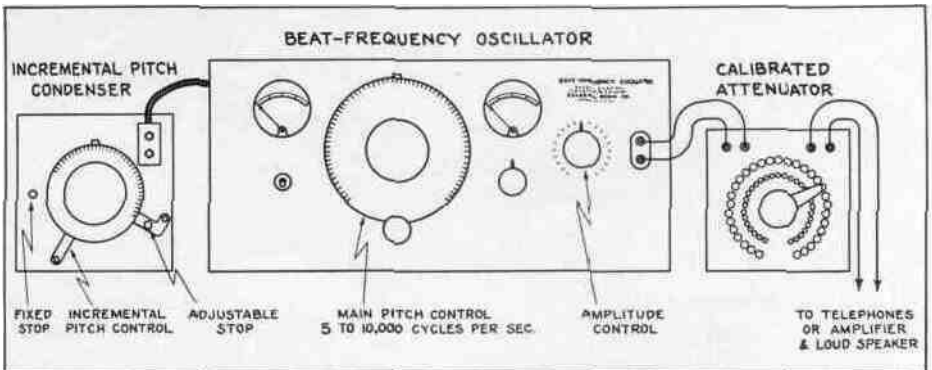

Studies involving intensity changes as well as pitch changes can be made by adding a calibrated attenuator to the apparatus shown on the opposite page

## LARGE SIZE PLUGS AND JACKS



674-D \$0.50

674-J \$0.25

674-P \$0.35

674-C \$0.20

Plug-in inductors made of 1/4-inch copper tubing can be sweated into the new TYPE 674-C Plug shown at the right. The cup is tinned. Illustration approximately one-half size

## DIAL PLATES



523-A

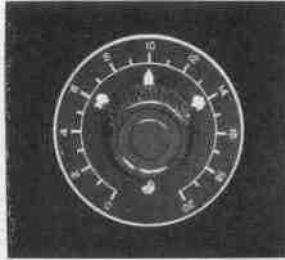

318-A

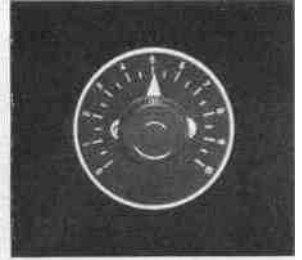

522-A

Dial plates made of etched nickel silver are now available for use with General Radio rheostat-potentiometers. TYPE 523-A is for TYPES 371, 314, and 471; TYPE 318-A is for TYPE 214; and TYPE 522-A is for TYPE 301.

Price: \$.35, each

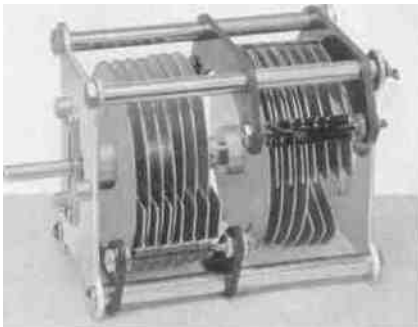

## A TWO-SECTION BAND-SPREAD CONDENSER

The new TYPE 756-A Condenser shown at the left is adapted for use in Colpitts oscillators in transmitters and frequency meters and in multi-circuit receivers. The maximum capacitance is 225 *uuf* and the minimum is adjustable between 100 *uuf* and 180 *uuf*. Price \$6.00.

## AN A-C POWER SUPPLY FOR BROADCAST FREQUENCY MONITORS

**T**HE General Radio Company has recently developed the TYPE 531-A Power Supply for use with the TYPE 575-D Piezo-Electric Oscillator. By means of this power pack, users of General Radio Frequency Monitors can dispense with batteries and operate the crystal oscillator from the alternating-current line.

The TYPE 531-A Power Supply includes two rectifiers with their associated filters. A copper-oxide rectifier is used in the 6-volt circuit which supplies current for the tube filament and the temperature-control relay. The

plate-supply rectifier is an 83 mercury-vapor tube. Both circuits are adequately filtered, and voltage adjustments are provided wherever necessary. Satisfactory operation can be obtained on line voltages between 105 and 120 volts, 60 cycles.

The whole assembly is mounted on a standard 19-inch relay-rack panel, 7 inches high. The panel is finished in black crackle lacquer to match the oscillator panel.

The price of the TYPE 531-A Power Supply is \$100.00, exclusive of the rectifier tube.

## VOLTAGE REGULATOR TRANSFORMER



This TYPE 440-R Transformer is a voltage-regulating device capable of handling a load of 100 volt-amperes. Its output voltage remains constant at a voltage between 112 and 115 volts for input voltage variations between 95 and 130 volts, 60 cycles, alternating current. Its price is \$40.00 complete with cord

## PRECISION RESISTORS WITH A HIGH POWER RATING

THE laboratory worker engaged in electrical measurements must often make a choice between the risk of burning out a precision resistor and using a less-accurate standard. Inevitably in experimental work, the requirements of many problems lie just beyond the safe limits of precision units.

The General Radio Company has recently designed a precision-type resistor capable of dissipating large amounts of power. This resistor, shown in Figure 1, consists of a mica card wound with resistance wire, clamped between two aluminum castings and insulated from them by two thin sheets of mica, the whole unit being supported on porcelain insulators. The aluminum castings are heavily ribbed to give a large heat-radiating surface.

The TYPE 525 Resistor is conservatively rated at 50 watts dissipation, although considerably more power can be dissipated for long periods without any damage to the resistor, since it is built to withstand high temperatures. A plot of temperature rise versus power



FIGURE 1. Type 525-L Resistor

dissipation is shown in Figure 2. These data were taken in still air, and if a fan is used to keep the air in motion, the temperature rise is much smaller. The increase in resistance with temperature is small, since the temperature coefficient is only 0.002% per degree at temperatures below 100° Centigrade.

Heavy-duty resistors are extensively used in the determination of the power output of radio transmitters. All such resistors have appreciable series inductance and shunt capacitance, and the resistance usually tends to rise with frequency as shunt resonance is ap-

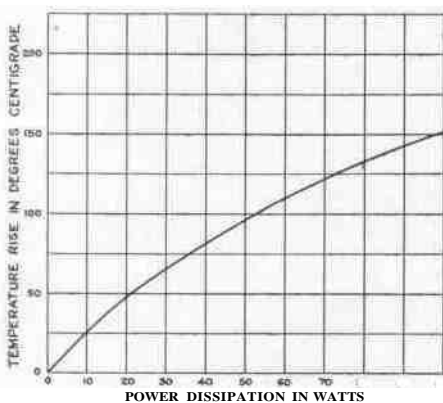

FIGURE 2. Temperature rise in a TYPE 525 Resistor as a function of power dissipation. This is essentially the same for all sizes

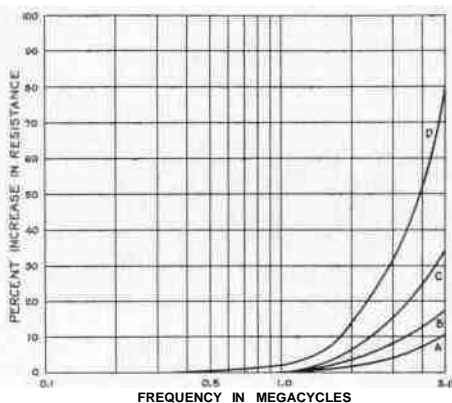

FIGURE 3. Frequency characteristics of 10-ohm (A and B) and of 40-ohm (C and D) TYPE 525 Resistors. Data for A and C were taken with the shield floating, B and D with the shield connected to one terminal

proached. Superimposed on this effect is the increase in resistance due to skin effect in the resistance wire itself.

That portion of the resistance which is due to reactance depends upon the equivalent inductance  $L = L - R^2C$ .\* For positive values of  $L$  the resistance (disregarding skin effect) increases with frequency, and for negative values of  $L$  it decreases.

The TYPE 525 Resistor shows extremely good radio-frequency charac-

teristics, particularly in the smaller sizes. Figure 3 shows the variation of resistance with frequency for two of these units.

Curves A and B are for the 10-ohm resistor and curves C and D for the 40-ohm size. A and C represent the resistance with the aluminum shield floating and curves B and D with the shield connected to one (continued on page 14)

\*"Frequency Characteristics," Robert F. Field, General Radio *Experimenter*, February, 1932.

### SALE OF DISCONTINUED RESISTANCE DEVICES

WHEN a new catalog is issued, some of our older instruments are dropped in favor of more up-to-date designs. It is seldom possible to avoid having small stocks of the discontinued items when this change is made, and a number of such instruments are now available. At least one of each of the resistance devices listed in the follow-

ing table are available at substantial reductions in price so long as the supply lasts. Additional specifications will be found in Catalog F.

Every item is new and carries with it the same promise of satisfactory operation as though the regular price were paid.

DECADE-RESISTANCE BOXES		Former Price	SALE PRICE
Type			
102-J	11,110 ohms in steps of 1 ohm—4 dials.	\$50.00	\$30.00

ATTENUATION BOXES		Former Price	SALE PRICE
Type			
329-H	55 db in steps of 0.5 db—H—600 ohms.....	\$140.00	\$50.00
339-K	55 db in steps of 0.5 db—H—6000 ohms.....	185.00	50.00
329-L	55 db in steps of 0.5 db—Balanced—H—6000 ohms..	190.00	50.00
329-P	22 db in steps of 0.2 db—Balanced—H—6000 ohms..	200.00	50.00
429-K	55 db in steps of 0.5 db—T—6000 ohms.....	175.00	50.00
429-R	22 db in steps of 0.2 db—T—6000 ohms.....	200.00	50.00

(Can Be Used as Attenuation Boxes)		Former Price	SALE PRICE
Type			
552-LA	30 db in steps of 15 db—L—50 ohms.....	\$28.00	\$15.00
552-LB	30 db in steps of 15 db—L—200 ohms.....	28.00	15.00
552-LC	30 db in steps of 15 db—L—500 ohms.....	28.00	15.00

## PRECISION RESISTORS WITH A HIGH POWER RATING

(Concluded)

terminal. In the latter case, the shunt capacitance is greater, resulting in a lower resonant frequency.

The characteristics of the 4-ohm unit are similar to those of the 10-ohm. The 600-ohm unit has an effective induc-

tance which is always negative. This factor is much larger than the skin effect, and the resistance will, therefore, decrease with frequency.

TYPE 525 Resistors are available in the following values:

### SPECIFICATIONS

<i>Type</i>	<i>Resistance</i>	<i>Accuracy</i>	<i>Code Word</i>	<i>Price</i>
525-C	4 ohms	0.1%	CABAL	\$8.00
525-D	10 ohms	0.1%	CABIN	8.00
525-F	40 ohms	0.1%	CABOB	8.00
525-H	100 ohms	0.1%	CADDY	8.00
525-L	600 ohms	0.1%	CADET	8.00

## SPECIAL PRICE ON CATHODE-RAY OSCILLOGRAPH TUBES

WE have five Western Electric No. 224-B Cathode-Ray Oscillograph Tubes in our laboratory stock that are now available for sale at a price well below the list price. They were purchased for use by our own engineering staff before development was completed on the General Radio Cathode-Ray Oscillograph and now have been set aside for them.

This is an excellent opportunity for interested laboratories to replenish their stocks of these tubes. No. 224-B is similar to and interchangeable with No. 224-A; the former taking a smaller filament current.

Each tube is in its original sealed carton. Price: \$30.00, each.

## AN OUTPUT TRANSFORMER FOR THE NEW 2A3 TUBES

THE new 2A3 amplifier tube should be of exceptional interest to all who are interested in high-quality reproduction, since two of these tubes in a push-pull output stage have a greater power handling ability than the usual push-pull pentode output stage and compare very favorably in this respect with Class B systems. In addition, a Class A out-

put stage, using the 2A3's, will generate considerably less harmonic distortion than either of these other two commonly-used output systems.

The General Radio Company has developed a new output transformer for use with these tubes. Because of its unusually high efficiency, nearly all of the output power is actually delivered to

the speaker. This transformer, which is known as the TYPE 541-D, has a practically flat characteristic from 20 to above 10,000 cycles per second. The secondary is tapped to match impedances from 1.5 to 12 ohms. This allows operation into any of the more usual types of dynamic speakers, or several speakers in parallel or in series.

The accompanying diagrams show an amplifier (and associated rectifier) designed particularly for the 2A3 tubes.

The actual quality delivered by an amplifier of this type is extremely good. The maximum power output is approximately 10 to 12 watts, which will overload two or three dynamic speakers of the usual type used in receiver sets. When operated at normal room volume, there is no fuzziness (as is often encountered in Class B amplifiers) and power peaks are easily taken care of, resulting in a brilliancy and realism in the reproduction which are quite amazing for an amplifier of these proportions.

— H. H. SCOTT



An amplifier using the new 2A3 tubes and parts described in the accompanying article

PRICE LIST		Price (each)
Type	Description	
541-D		\$7.50
541-J		7.50
349	4-Prong Socket (3 req'd)	.35
438	5-Prong Socket (2 req'd)	.35
	C <sub>1</sub> —Pyranol Condenser, 4 uf; peak voltage	
<b>1 9 8 0</b>		
*AD18	T <sub>1</sub>	6.60
		3.00
*AD20	T <sub>2</sub>	5.05
*AD30	L <sub>1</sub>	4.55
*AD40	L <sub>2</sub>	4.55

Any standard by-pass condensers and resistors having satisfactory voltage and current ratings can be used.

\*These are manufactured by the Delta Manufacturing Company and are obtainable from General Radio at the regular net prices given above.

Wiring diagram for the 2A3 amplifier shown above. Note that other standard input transformers are available, for use on 500-ohm lines, for instance

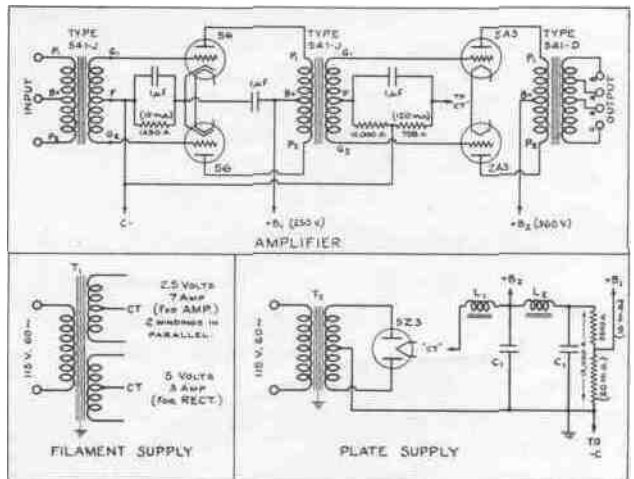

## USING THE EDGERTON STROBOSCOPE IN AUTOMOTIVE RESEARCH

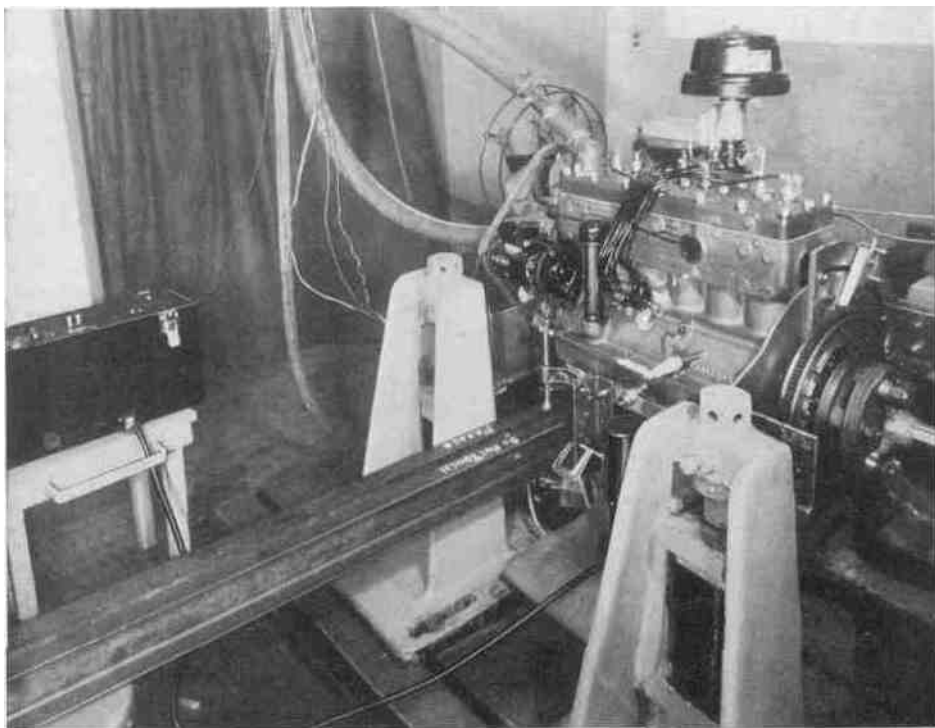

Chrysler engineers measure crankshaft whip and vibration with the Edgerton Stroboscope. For an interesting description of the method, see page 75 of *Instruments* for April, 1933. Reprints can be had from General Radio Company without charge



**THE GENERAL RADIO COMPANY** mails the *Experimenter*, without charge, each month to engineers, scientists, and others interested in communication-frequency measurement and control problems. Please send requests for subscriptions and address-change notices to the

**GENERAL RADIO COMPANY**

30 State Street - Cambridge A, Massachusetts